

# Installation manual

## Washer extractor

**WH6-7CV, WH6-8CV, WH6-11CV, WH6-14CV,  
WH6-20CV, WH6-27CV, WH6-33CV**

**Type W3....**

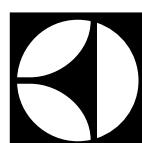

**Electrolux**  
PROFESSIONAL



# Contents

## Contents

1	Safety Precautions .....	5
1.1	General safety information.....	6
1.2	Commercial use only.....	6
1.3	Copyright .....	6
1.4	Ergonomics certification .....	6
1.5	Symbols.....	7
2	Warranty terms and exclusions.....	8
3	Technical data.....	9
3.1	Drawing .....	9
3.1.1	WH6-7CV, WH6-8, WH6-11CV .....	9
3.1.2	WH6-14CV .....	10
3.1.3	WH6-20CV, WH6-27CV, WH6-33CV .....	11
3.2	Technical data .....	12
3.3	Connections .....	12
4	Setup .....	13
4.1	Unpacking.....	13
4.1.1	WH6-7, WH6-8, WH6-11 .....	13
4.1.2	WH6-14, WH6-20, WH6-27, WH6-33 .....	15
4.2	Recycling instruction for packaging .....	17
4.3	Siting .....	18
4.4	Mechanical installation .....	18
5	Marine installation .....	20
6	Water connection .....	21
7	Connection of external dosing systems .....	23
7.1	Jetsave and Dosave.....	23
7.1.1	Connection of the tube.....	23
8	Drain connection .....	24
9	Electrical connection.....	25
9.1	Electrical installation .....	25
9.2	Electrical connections .....	25
9.3	Machine connection with ferrite.....	28
9.3.1	WH6-14CV, WH6-20CV, WH6-27CV, WH6-33CV .....	28
9.4	Machine connection .....	29
9.5	Connector with termination resistor .....	29
9.6	Connection of external functions .....	30
9.6.1	Outputs .....	30
9.6.2	Inputs.....	31
9.7	Functions for I/O-boards.....	32
9.7.1	Enable start (22A, 22B).....	32
9.7.2	Remote start/stop (22A, 22B).....	33
9.7.3	External coin meter/Central payment (22A, 22B).....	34
9.7.4	Pause (22A, 22B).....	35
9.7.5	Dual heating (22A, 22B).....	36
9.7.6	Trigger signals for dosing system without saving (22B).....	37
9.7.7	Dual heating and Trigger signals for dosing system without saving (22B).....	38
9.8	Converting heating elements .....	39
9.8.1	WH6-7, WH6-8 and WH6-11 can be converted from 400-415V 3AC to 230-240V 1AC with reduced power .....	39
9.8.2	WH6-14 can be converted from 380-415V 3N AC to 220-240V 1N AC with reduced power .....	40
10	Steam connection .....	41
11	Steam connection for dual heating (option for WH6-14, WH6-20, WH6-27, WH6-33 ) .....	43
12	Machine with level tube and test tap (option for WH6-14, WH6-20, WH6-27, WH6-33 ) .....	46
12.1	Setup/Using .....	46
13	At first power up .....	47
14	Function check.....	48
15	Disposal information .....	49
15.1	Disposal of appliance at end of life .....	49
15.2	Disposal of packing.....	49

# Contents

---

The manufacturer reserves the right to make changes to design and component specifications.

## 1 Safety Precautions

- Servicing shall be carried out only by authorized personnel.
- Only authorized spare parts, accessories and consumables shall be used.
- Only use detergent intended for water-wash of textiles. Never use dry cleaning agents.
- The machine shall be connected with new water hoses. Re-used water hoses must not be used.
- The machine's door lock must under no circumstances be bypassed.
- If the machine develops a fault, this must be reported to the person in charge as soon as possible. This is important both for your safety and that of others.
- DO NOT MODIFY THIS APPLIANCE.
- When performing service or replacing parts, the power must be disconnected.
- When the power is disconnected, the operator must see that the machine is disconnected (that the plug is removed and remains removed) from any point to which he has access. If this is not possible, due to the construction or installation of the machine, a disconnection with a locking system in the isolated position shall be provided.
- In accordance with the wiring rules: mount a multi-pole switch prior to the machine to facilitate installation and service operations.
- If different rated voltages or different rated frequencies (separated by a /) are stated at the machine data plate, instructions for adjusting the appliance for operation at the required rated voltage or rated frequency are stated in the installation manual.
- Stationary appliances not fitted with means for disconnection from the supply mains having a contact separation in all poles that provide full disconnection under overvoltage category III, means for disconnection must be incorporated in the fixed wiring in accordance with the wiring rules.
- The openings in the base, shall not be obstructed by a carpet.
- Maximum mass of dry cloth: WH6–7CV: 7.5 kg, WH6–8CV: 8.5 kg, WH6–11CV: 11.5 kg, WH6–14CV: 14.5 kg, WH6–20CV: 21 kg, WH6–27CV: 27.5 kg, WH6–33CV: 36.5 kg.
- A-weighted emission sound pressure level at working stations:
  - Wash: WH6–7CV: <70 dB(A), WH6–8CV: <70 dB(A), WH6–11CV: <70 dB(A), WH6–14CV: <70 dB(A), WH6–20CV: <70 dB(A), WH6–27CV: <70 dB(A), WH6–33CV: <70 dB(A).
  - Extraction: WH6–7CV: <70 dB(A), WH6–8CV: <70 dB(A), WH6–11CV: <70 dB(A), WH6–14CV: <70 dB(A), WH6–20CV: <70 dB(A), WH6–27CV: <70 dB(A), WH6–33CV: <70 dB(A).
- Maximum inlet water pressure: 1000 kPa
- Minimum inlet water pressure: 50 kPa
- Additional requirements for the following countries; AT, BE, BG, HR, CY, CZ, DK, EE, FI, FR, DE, GR, HU, IS, IE, IT, LV, LT, LU, MT, NL, NO, PL, PT, RO, SK, SI, ES, SE, CH, TR, UK:
  - The appliance can be used in an area open to the public.  
If installation is made in a public area, it is only allowed to select the below segments:  
APARTMENT AUTO DOSING  
APARTMENT MANUAL DOSING  
APARTMENT BUILDING MATS

LAUNDROMAT/LAUNDERETTE

LAUNDROMAT/LAUNDERETTE WASCOMAT

LAUNDROMAT/LAUNDERETTE MENCH

CAMPING/MARINA

OTHER SELF SERVICE

- This appliance can be used by children aged from 8 years and above and persons with reduced physical, sensory or mental capabilities or lack of experience and knowledge if they have been given supervision or instruction concerning use of the appliance in a safe way and understand the hazards involved. Children shall not play with the appliance. Cleaning and user maintenance shall not be made by children without supervision.
- Additional requirements for other countries:
  - This appliance is not intended for use by persons (including children) with reduced physical, sensory or mental capabilities, or lack of experience and knowledge, unless they have been given supervision or instruction concerning use of the appliance by a person responsible for their safety. Children should be supervised to ensure that they do not play with the appliance.
  - This appliance is intended to be used in household and similar applications such as: (IEC 60335-2-7) staff kitchen areas in shops, offices and other working environments, farm houses, by clients in hotels, motels and other residential type environments, bed and breakfast type environments, areas for communal use in blocks of flats or in laundrettes.

### 1.1 General safety information

The machine is only intended for water-wash use.

Do not hose down the machine with water.

In order to prevent damage to the electronics (and other parts) that may occur as the result of condensation, the machine should be placed in room temperature for 24 hours before being used for the first time.

### 1.2 Commercial use only

The machine/machines covered by this manual is/are made for commercial and industrial use only.

### 1.3 Copyright

This manual is intended solely for consultation by the operator and can only be given to third parties with the permission of Electrolux Professional AB company.

### 1.4 Ergonomics certification

The human body is designed for movement and activity but physical stress injuries as a result of static and repetitive movements or unfavorable working postures may occur.

The ergonomic features of your product, the ones which may influence your physical and cognitive interaction with it, have been assessed and certified.

A product which exhibits ergonomic features, in fact, shall fulfil specific ergonomic requirements, belonging to three different areas: Polytechnic, Biomedical and Psychosocial (usability and satisfaction).

For each of these areas, specific tests with real users have been performed. The product was therefore compliant with the ergonomic acceptability criteria requested by the standards.

In case several machines are managed by the same operator the repetitive movements will increase and as a consequence of this the related biomechanical risk will increase exponentially.



Follow the below recommendations to avoid, as much as possible, operators acquiring bodily injury.

- The models WH6-14, WH6-20, WH6-27 and WH6-33 should be connected to automatic dosing of chemicals or equipped with detergent dosing dispenser on the front.
- For the models WH6-7, WH6-8 and WH6-11 the possible postural risks are the interaction with the door handle in case the machine is not placed on a base. Place the machine on a base instead of directly on the floor so that the operator does not need to bend his/her back unnecessarily when loading and unloading.

Minimum suggested height of bases is 300 mm.

- The hand force needed to open and close the washing machine door can be perceived too high the first times the machine is used due to the initial high gasket pressure. Therefore, it is recommended not to use only the fingers but also the palm when closing and opening the door. The gasket pressure will be lower after some days of use.
- Make sure there are suitable trolleys or baskets for loading, unloading and transportation.
- Organize job rotation in the working place in the case several machines are managed by the same operator.

## 1.5 Symbols

	Caution
	Caution, high voltage
	Read the instructions before using the machine

## 2 Warranty terms and exclusions

If the purchase of this product includes warranty coverage, warranty is provided in line with local regulations and subject to the product being installed and used for the purposes as designed, and as described within the appropriate equipment documentation.

Warranty will be applicable where the customer has used only genuine spare parts and has performed maintenance in accordance with Electrolux Professional AB user and maintenance documentation made available in paper or electronic format.

Electrolux Professional AB strongly recommends using Electrolux Professional AB approved cleaning, rinse and descaling agents to obtain optimal results and maintain product efficiency over time.

The Electrolux Professional AB warranty does not cover:

- service trips cost to deliver and pick up the product;
- installation;
- training on how to use/operate;
- replacement (and/or supply) of wear and tear parts unless resulting from defects in materials or workmanship reported within one (1) week from the failure;
- correction of external wiring;
- correction of unauthorized repairs as well as any damages, failures and inefficiencies caused by and/or resulting from:
  - insufficient and/or abnormal capacity of the electrical systems (current/voltage/frequency, including spikes and/or outages);
  - inadequate or interrupted water supply, steam, air, gas (including impurities and/or other that does not comply with the technical requirements for each appliance);
  - plumbing parts, components or consumable cleaning products that are not approved by the manufacturer;
  - customer's negligence, misuse, abuse and/or non-compliance with the use and care instructions detailed within the appropriate equipment documentation;
  - improper or poor: installation, repair, maintenance (including tampering, modifications and repairs carried out by third parties not authorized third parties) and modification of safety systems;
  - Use of non-original components (e.g.: consumables, wear and tear, or spare parts);
  - environment conditions provoking thermal (e.g. overheating/freezing) or chemical (e.g. corrosion/oxidation) stress;
  - foreign objects placed in- or connected to- the product;
  - accidents or force majeure;
  - transportation and handling, including scratches, dents, chips, and/or other damage to the finish of the product, unless such damage results from defects in materials or workmanship and is reported within one (1) week of delivery unless otherwise agreed;
- product with original serial numbers that have been removed, altered or cannot be readily determined;
- replacement of light bulbs, filters or any consumable parts;
- any accessories and software not approved or specified by Electrolux Professional AB.

Warranty does not include scheduled maintenance activities (including the parts required for it) or the supply of cleaning agents unless specifically covered within any local agreement, subject to local terms and conditions.

Check on Electrolux Professional AB website the list of authorized customer care.

### 3 Technical data

#### 3.1 Drawing

##### 3.1.1 WH6-7CV, WH6-8, WH6-11CV

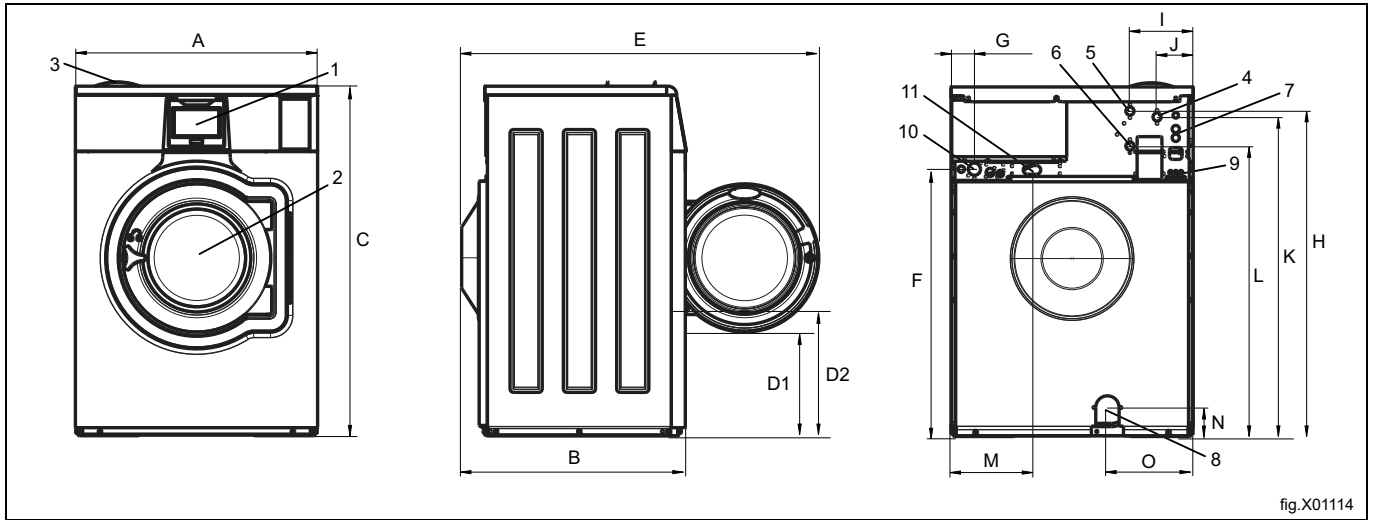

1	Display
2	Door opening, WH6-7CV, WH6-8CV: $\varnothing$ 310 mm, WH6-11: $\varnothing$ 365 mm
3	Detergent container
4	Cold water
5	Hot water
6	Cold/Hot water or Re-used water with network pressure (option)
7	Re-used water from tank/pump or Liquid detergent supply
8	Drain
9	Liquid detergent supply
10	Electrical connection
11	Steam connection

mm	A	B	C	D1	D2	E	F	G
WH6-7CV	720	720	1120	360	425	1135	835	80
WH6-8CV	720	720	1120	360	425	1135	835	80
WH6-11CV	830	770	1200	365	435	1240	920	80

mm	H	I	J	K	L	M	N	O
WH6-7CV	1035	215	125	1015	915	280	100	240
WH6-8CV	1035	215	125	1015	915	280	100	240
WH6-11CV	1120	215	125	1100	1000	280	105	295

## 3.1.2 WH6-14CV

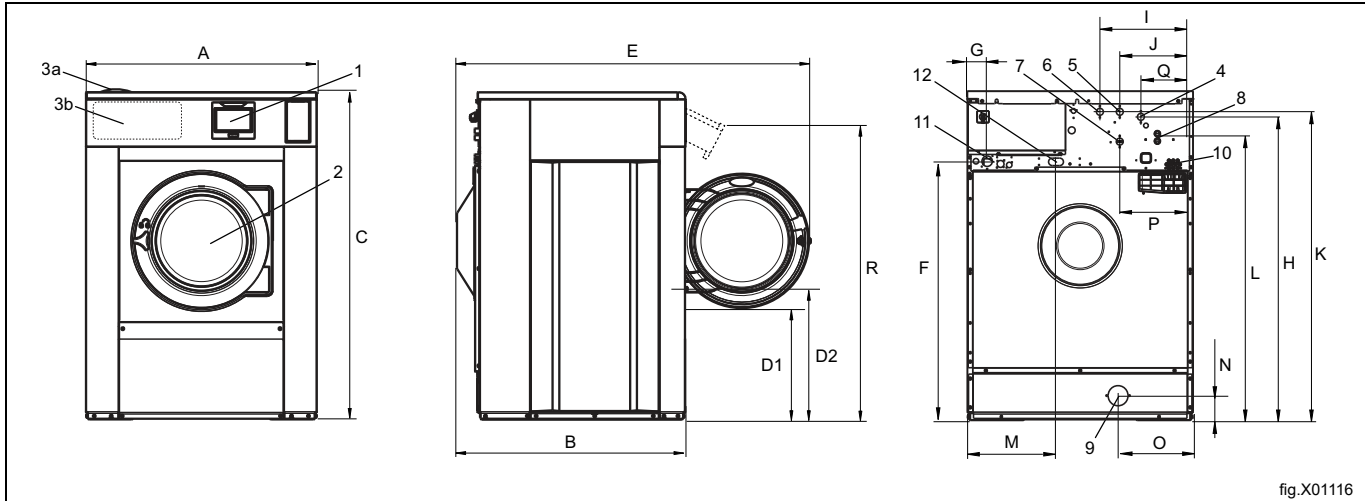

fig.X01116

1	Display
2	Door opening, WH6-14CV: $\varnothing$ 395 mm
3a	Detergent container
3b	Detergent container (option)
4	Cold/Hot water (Detergent container)
5	Cold water
6	Hot water
7	Cold/Hot water or Re-used water with network pressure (option)
8	Re-used water from tank/pump or Liquid detergent supply
9	Drain
10	Liquid detergent supply
11	Electrical connection
12	Steam connection

mm	A	B	C	D1	D2	E	F	G
WH6-14CV	910	820	1330	440	515	1310	1050	80

mm	H	I	J	K	L	M	N	O
WH6-14CV	1245	375	295	1225	1125	360	105	305

mm	P	Q	R
WH6-14CV	295	210	1215

3.1.3 WH6-20CV, WH6-27CV, WH6-33CV

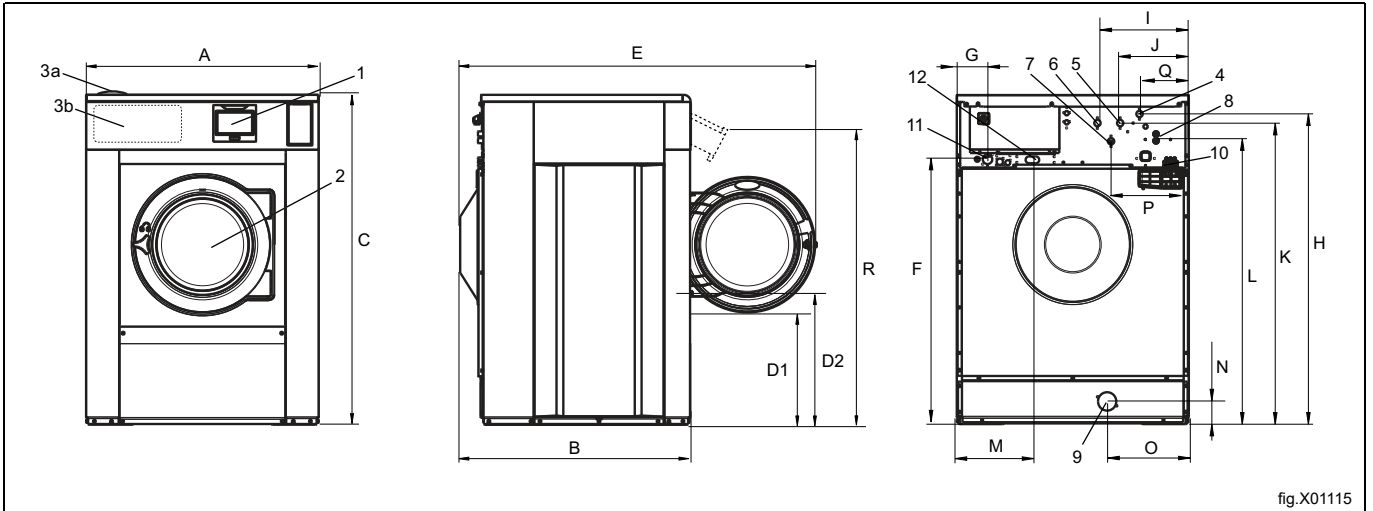

fig.X01115

1	Display
2	Door opening, WH6-20CV, WH6-27CV, WH6-33CV: $\varnothing$ 435 mm
3a	Detergent container
3b	Detergent container (option)
4	Cold/Hot water (Detergent container)
5	Cold water
6	Hot water
7	Cold/Hot water or Re-used water with network pressure (option)
8	Re-used water from tank/pump or Liquid detergent supply
9	Drain
10	Liquid detergent supply
11	Electrical connection
12	Steam connection

mm	A	B	C	D1	D2	E	F	G
WH6-20CV	970	945	1415	470	555	1480	1135	150
WH6-27CV	1020	990	1450	500	580	1525	1170	135
WH6-33CV	1020	1135	1450	500	580	1665	1170	135

mm	H	I	J	K	L	M	N	O
WH6-20CV	1330	400	300	1290	1210	350	105	335
WH6-27CV	1365	400	300	1325	1245	335	105	360
WH6-33CV	1365	400	300	1325	1245	335	105	360

mm	P	Q	R
WH6-20CV	330	215	1300
WH6-27CV	340	215	1335
WH6-33CV	340	215	1335



## 4 Setup

### 4.1 Unpacking

#### 4.1.1 WH6-7, WH6-8, WH6-11

##### Removal of the bolts between the machine and pallet

Remove the front and rear panel.

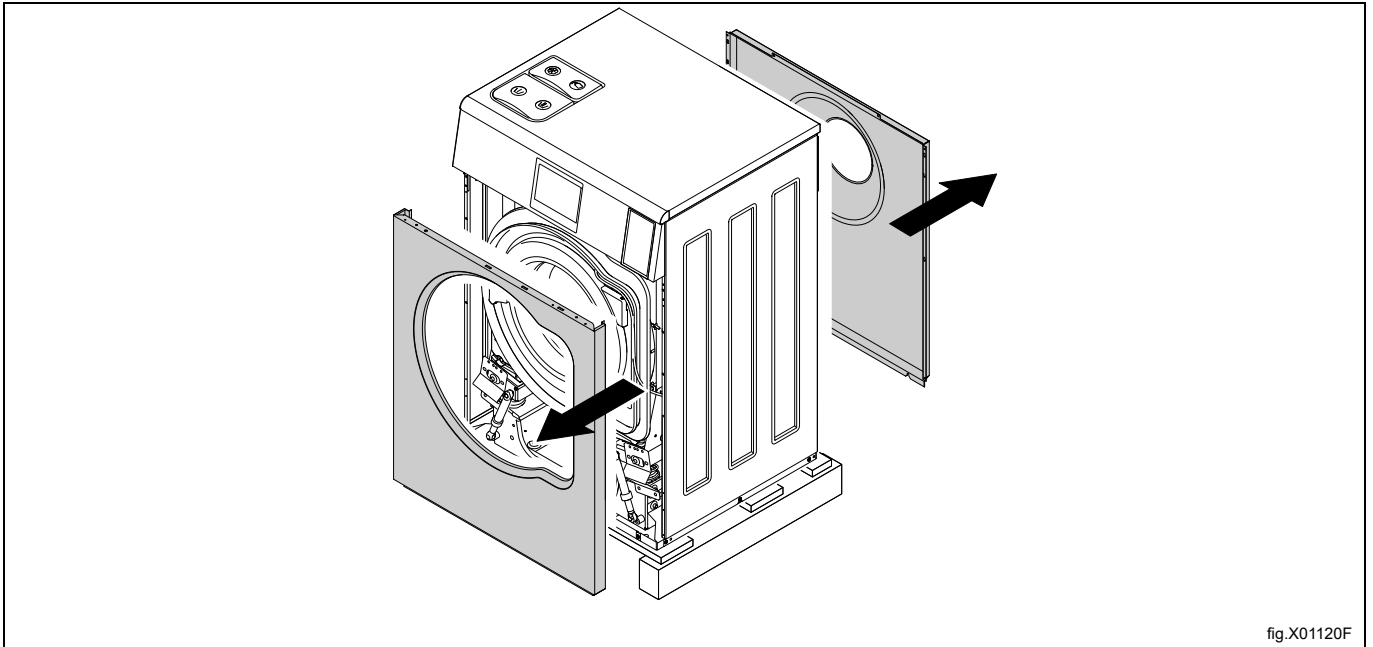

Remove the bolts between the machine and pallet.

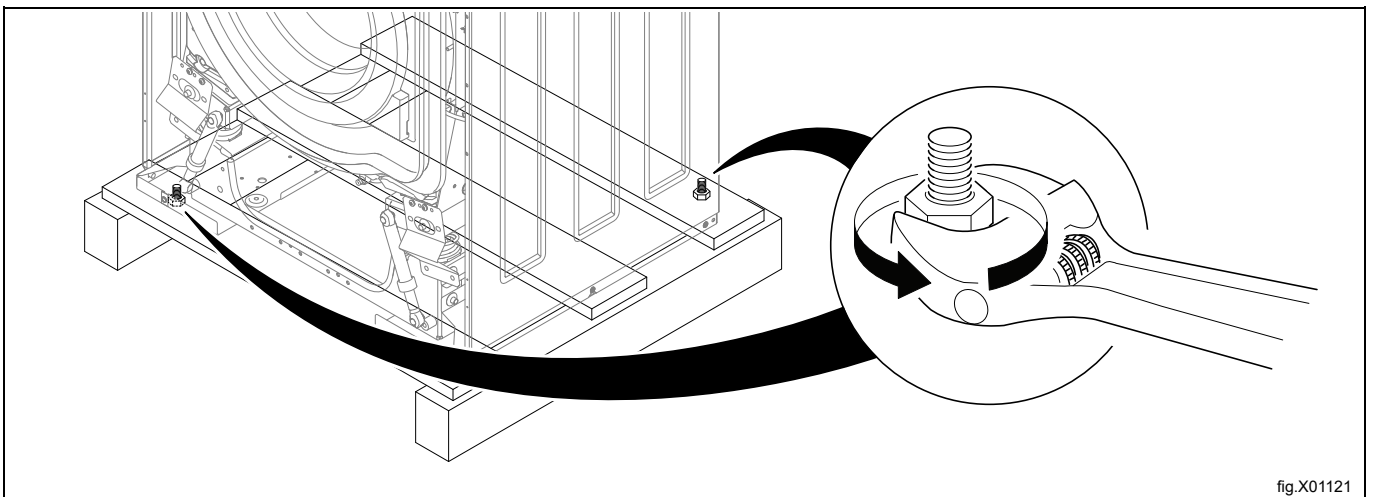

Remove the machine from the pallet.

#### **Note!**

**When moving the machine, handle it with care. Make sure that the machine does not come down on the floor with either of the rear corners first. The side panel of the machine can be damaged.**

**Removal of the transport securities**

When the machine is placed in final or close to final position, remove the four transport supports. Save the transport supports if the machine needs to be moved in the future.

**Note!**

Once the transport supports have been removed, handle the machine carefully to avoid damage to the suspension components.

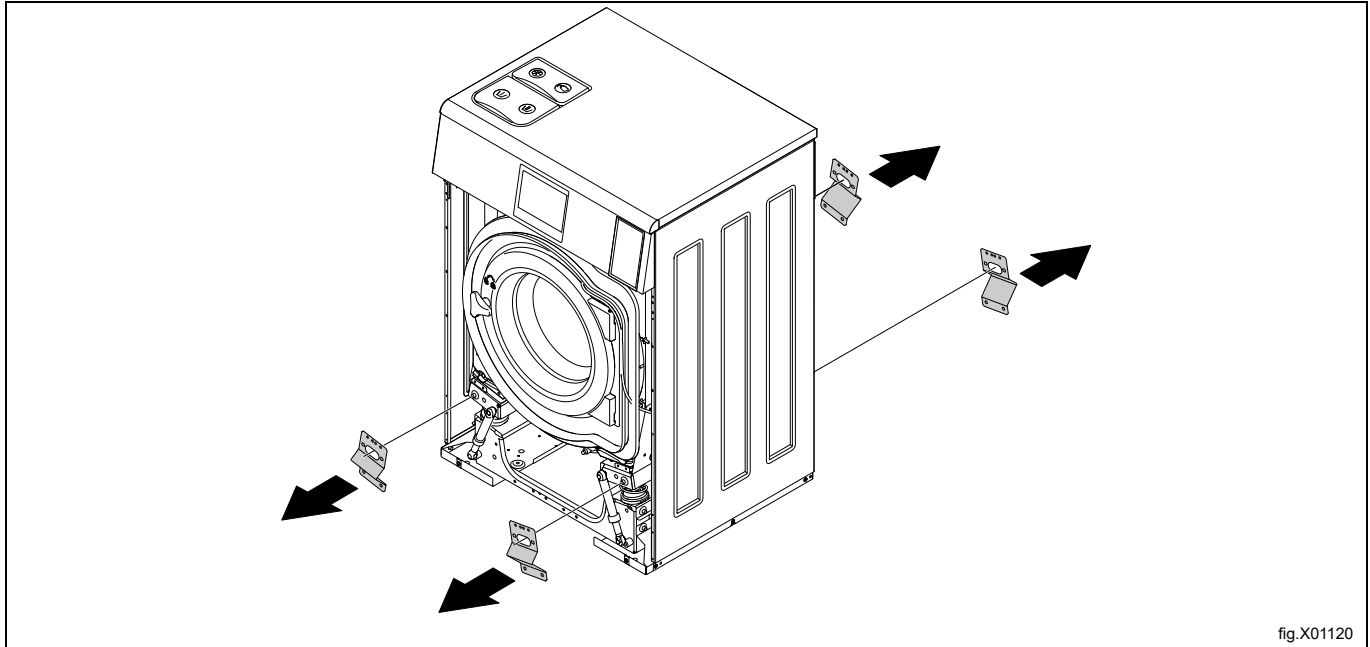

When the machine is placed in final position, mount the supporting feet. (If the machine is not to be mounted on a base).

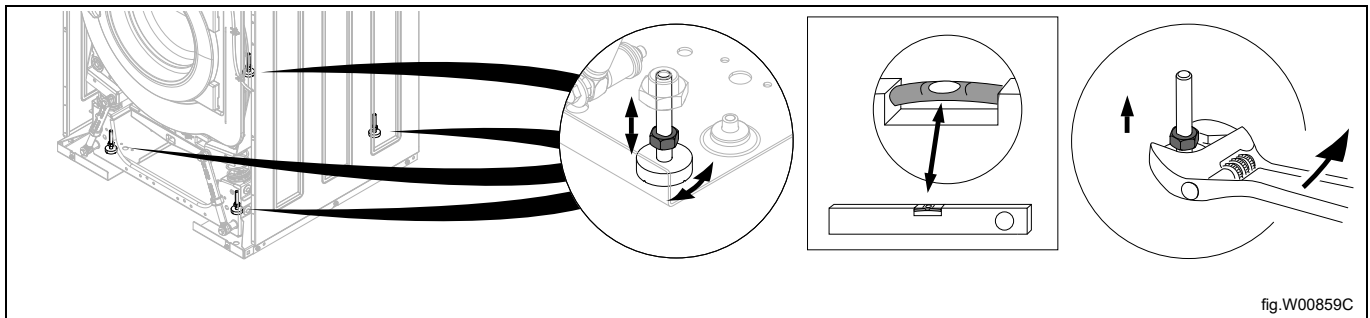

**4.1.2 WH6-14, WH6-20, WH6-27, WH6-33**

Removal of the bolts between the machine and pallet

**Note!**

Two persons are recommended for the unpacking.

Remove the side panels.

Remove the front and rear panel.

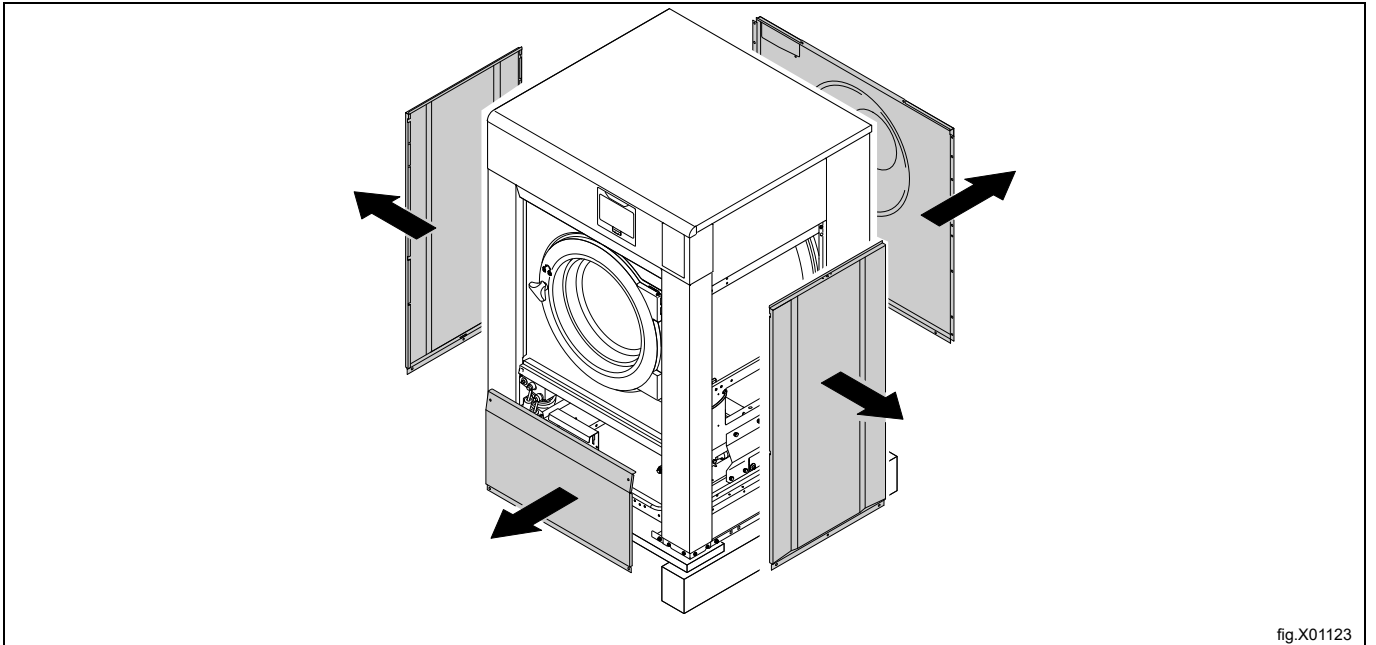

fig.X01123

Remove the bolts between the machine and pallet.

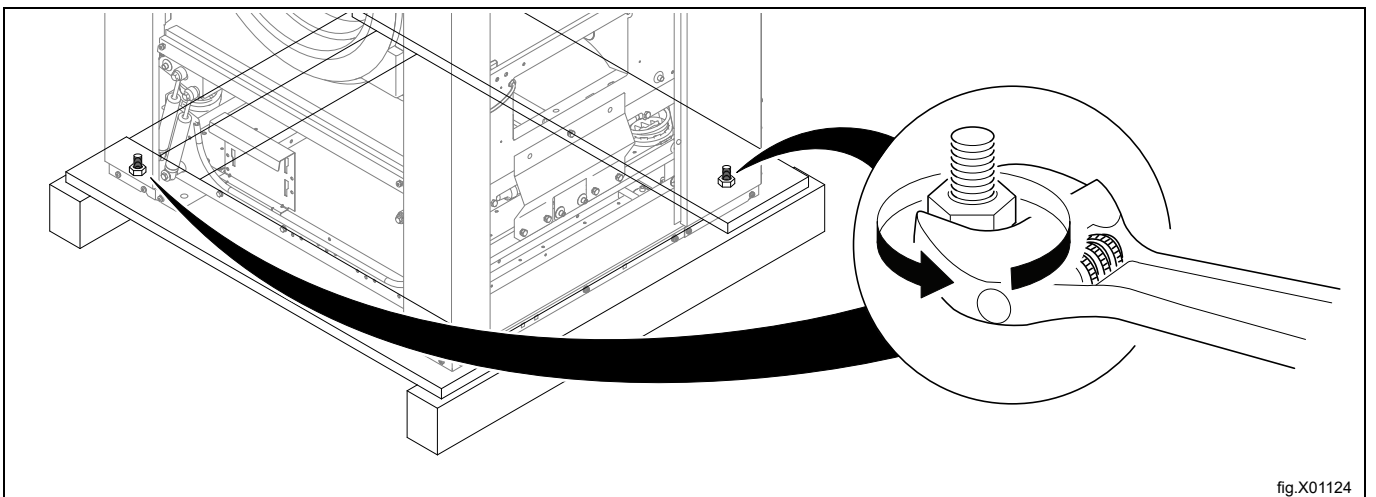

fig.X01124

Remove the machine from the pallet.

### Removal of the transport securities

When the machine is placed in final or close to final position, remove the four transport supports. Save the transport supports if the machine needs to be moved in the future.

#### Note!

Once the transport supports have been removed, handle the machine carefully to avoid damage to the suspension components.

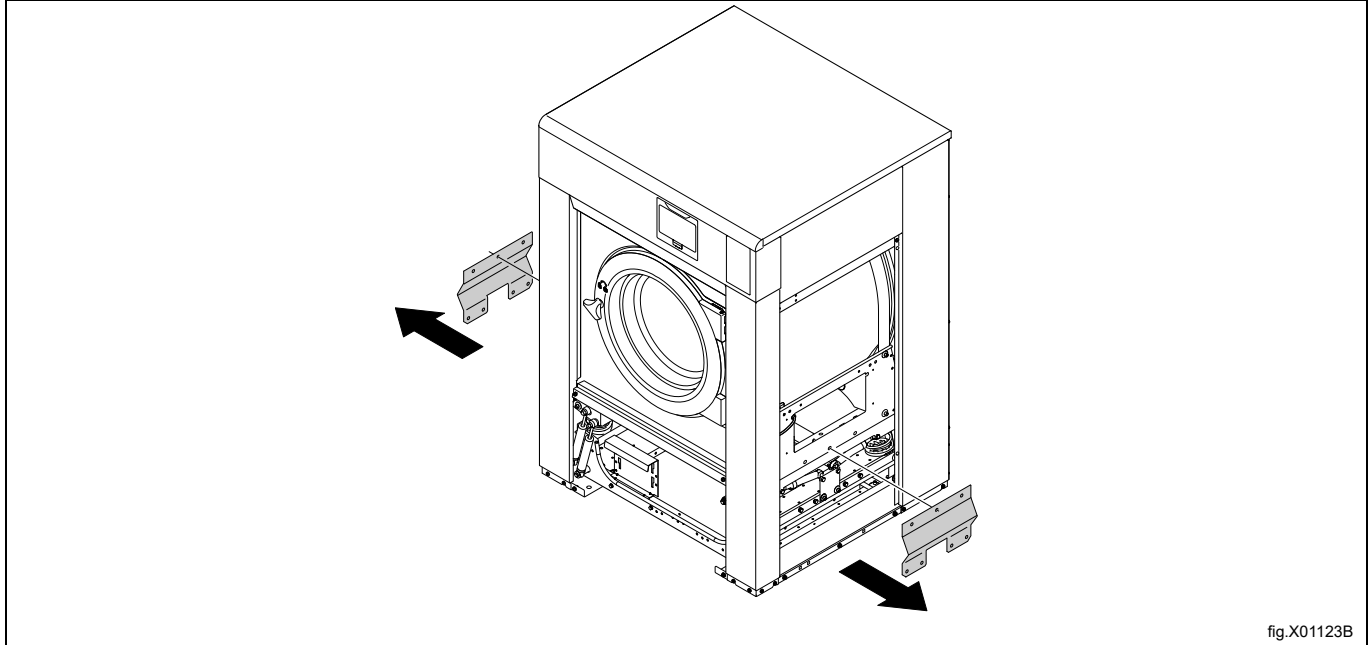

When the machine is placed in final position, mount the supporting feet. (If the machine is not to be mounted on a base).

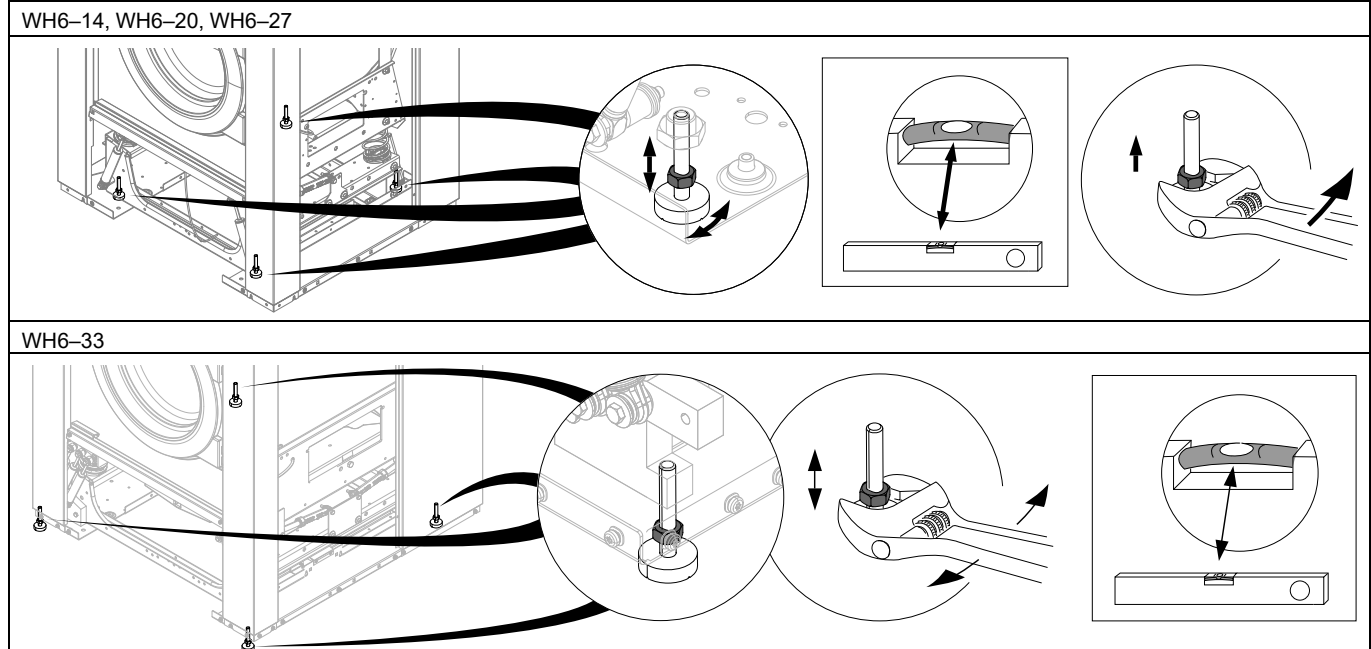

4.2 Recycling instruction for packaging

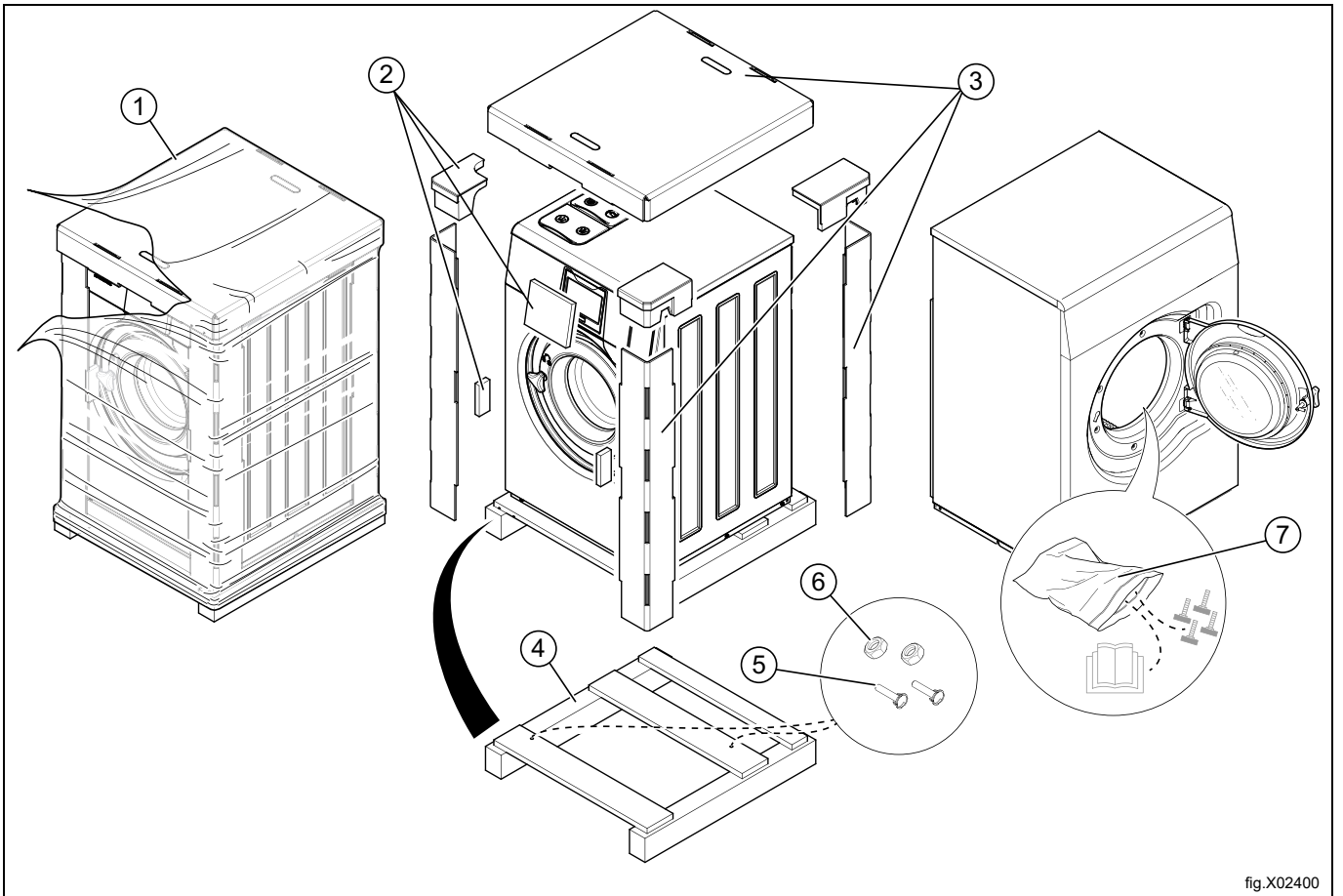

fig.X02400

Fig.	Description	Code	Type
1	Wrapping film	LDPE 4	Plastics
2	Corner protection	PS 6	Plastics
3	Cardboard packaging	PAP 20	Paper
4	Pallet	FOR 50	Wood
5	Screw	FE 40	Steel
6	Nut	FE 40	Steel
7	Plastic bag	PET 1	Plastics

### 4.3 Siting

Install the machine close to a floor drain or open drain.

The machine should be positioned so that there is plenty of room for working, both for the user and service personnel.

The figure shows minimum distance to a wall and/or other machines. Failure to respect the prescribed distances will prevent easy access for maintenance and service operations.

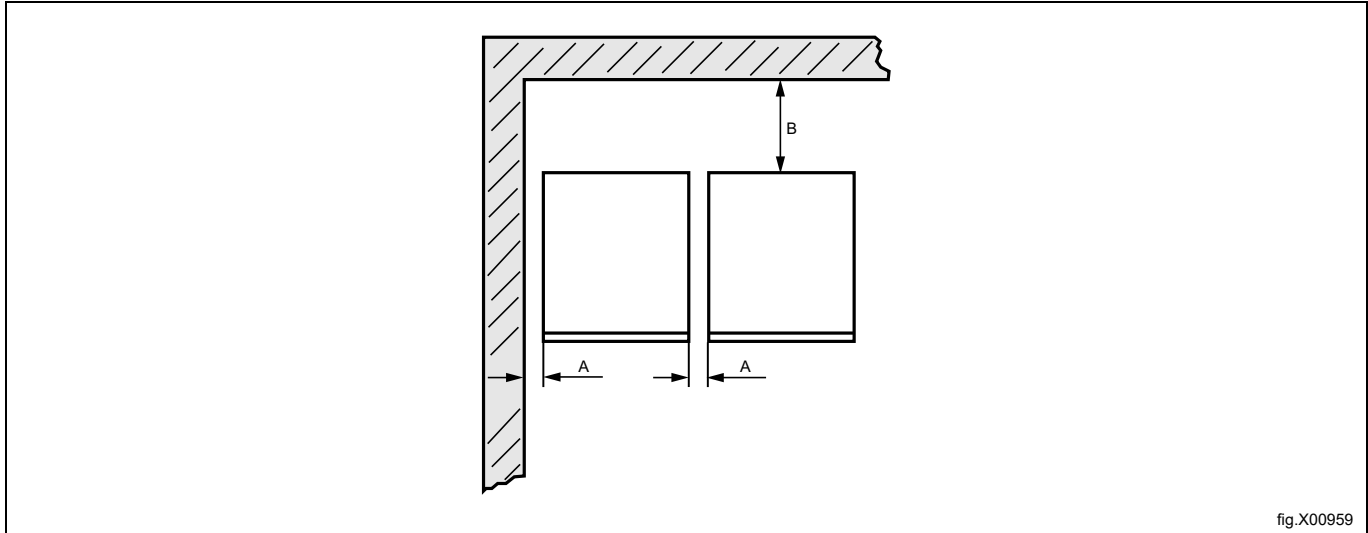

fig.X00959

A	25 mm
B	500 mm

### 4.4 Mechanical installation

If the machine is not to be mounted on a base the machine must be fastened to the floor with the enclosed expansion bolts.

The table shows the correct position of feet and drilling points.

WH6-7-WH6-11: Mark and drill two holes (∅ 8 mm) about 40 mm deep in position (1).

WH6-14-WH6-33: Mark and drill two holes (∅ 10 mm) about 50 mm deep in position (1).

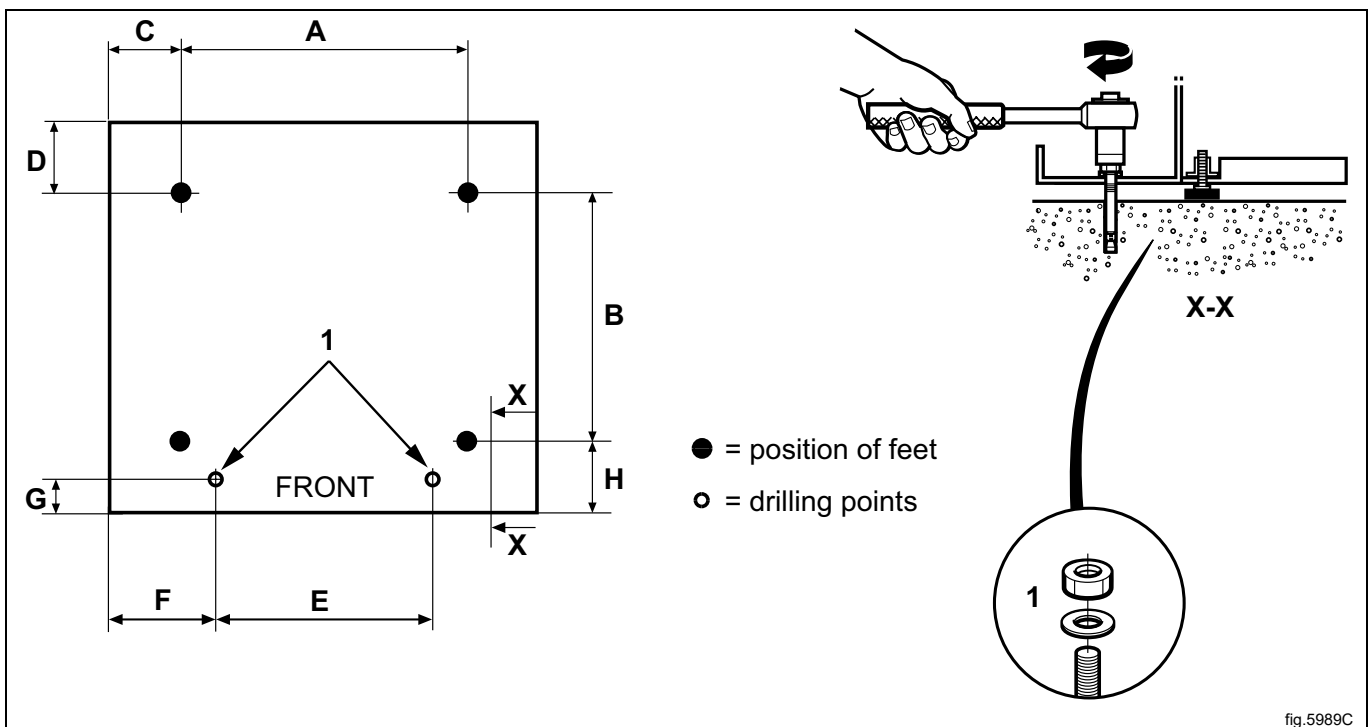

fig.5989C

mm	A	B	C	D	E	F	G	H
WH6-7	495	460	110	125	375	170	40	100
WH6-8	495	460	110	125	375	170	40	100
WH6-11	575	465	130	140	455	185	35	95
WH6-14	635	490	135	175	515	195	65	125
WH6-20	715	545	125	205	595	185	65	125
WH6-27	790	615	115	180	670	175	65	125
WH6-33	900	835	60	140	670	175	60	80

Place the machine over the two drilled holes. The holes are at the front of the machine.

Level the machine with the feet of the machine. Screw in the feet as much as possible before starting to level the machine. This will make the machine stand steadier.

The maximum height adjustment of the feet is 30 mm for WH6-7-WH6-11 and 50 mm for WH6-14-WH6-33.

Insert the expansion bolts (1) into the holes drilled in the floor. Fit the washers and nuts and tighten with tightening torque 5 Nm.



It is of the upmost importance that the machine is placed in level, from side to side as well as front to rear. Remount the panels when ready.

## 5 Marine installation



The maximum inclination allowed in any direction is 4°.



To ensure steadiness of the machine; the machine must be fastened to the floor.

## 6 Water connection

All water intake connections to the machine should be fitted with manual shut-off valves and filters, to facilitate installation and servicing.

Water pipes and hoses should be flushed clean before installation.

The machine shall be connected with new water hoses. Re-used water hoses must not be used.

Hoses are to be of an approved type and grade and comply with IEC 61770 and any applicable local regulations.

After installation hoses must hang in gentle arcs.

All connectors present on the machine must be connected. The table shows the possible connection options, which will depend on the water types to be connected to the machine. Information is also available on the panel above the connections.

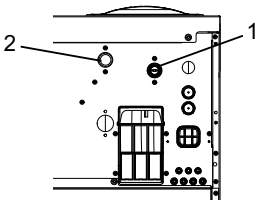
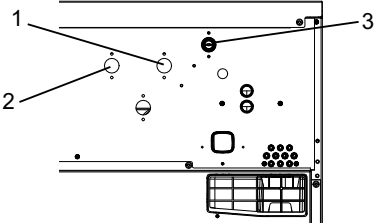
	Water type	Water connection
	WH6-7, WH6-8, WH6-11 • Cold and hot	WH6-7, WH6-8, WH6-11 1. Cold (for detergent dispenser) 2. Hot
	WH6-14, WH6-20, WH6-27, WH6-33 • Cold and hot	WH6-14, WH6-20, WH6-27, WH6-33 1. Cold 2. Hot 3. Cold (for detergent dispenser) / Hot

There is also an extra water valve which can be used for hard water if soft water is connected to 1.

This valve can also be used for water re-use from tank.

If pump is used, it is only a water connection without valve.

Remove the three plastic covers (A).

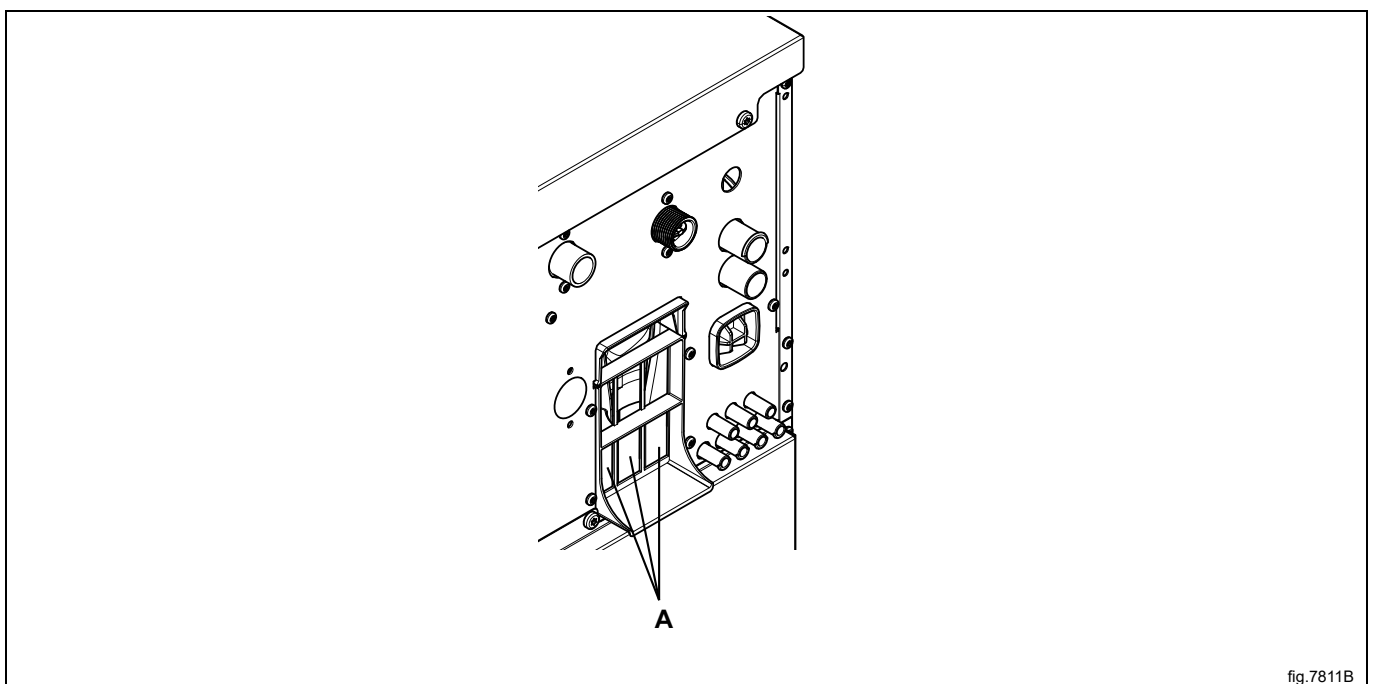

fig.7811B

Water pressure:

Continuous operating pressure: 50–800 kPa (0.5-80 kp/cm<sup>2</sup>)

Maximum: 1000 kPa (10 kp/cm<sup>2</sup>)

Recommended: 200–600 kPa (2–6 kp/cm<sup>2</sup>)

**Note!**

**If the water pressure is below the minimum value, the wash result can not be guaranteed for certain program.**

For WRAS-approved machines; always check connection requirements on WRAS website.

For KIWA-approved machines; always check connection requirements on KIWA website.

For NSF-approved machines; always check connection requirements on NSF website.

**Plumbing**

This machine is approved for all UK applications as suitable for category 5.

The product is listed in the WRAS regulations advisory scheme directory and is suitable for direct connection to mains drinking water. No special plumbing arrangements e.g. break tanks are required.

Water Council approved double check valves should be fitted in between the stopcocks and the water inlet hoses.

**FOR AUSTRALIA:**

The appliance shall be installed in accordance with the Plumbing Code of Australia (the PCA).

The appliance need to be installed using dual check valves.

Contact details for after sales service: [service.au@electroluxprofessional.com](mailto:service.au@electroluxprofessional.com)

## 7 Connection of external dosing systems

Depending on which type of dosing system that is going to be connected, follow the instructions enclosed with the dosing system.

The following is some preparations that can be made on the machine.

### 7.1 Jetsave and Dosave

#### 7.1.1 Connection of the tube

The machine is prepared for connection to the dosing systems Jetsave and Dosave.

The connections are closed at delivery. Open any of the connections that shall be used by drilling a hole where the tube shall be connected.

#### Note!

**Make sure there is no burrs left after drilling. When removing burrs make sure burrs does not fall into the siphon breaker.**

A =  $\varnothing$  17 mm (used for dosing systems).

B =  $\varnothing$  6 mm (used for dosing systems).

C = Only used for flush manifold. (Separate instructions enclosed when ordering).

Depending on which detergent container that is used on the machine, the rear view can be either of the examples below.

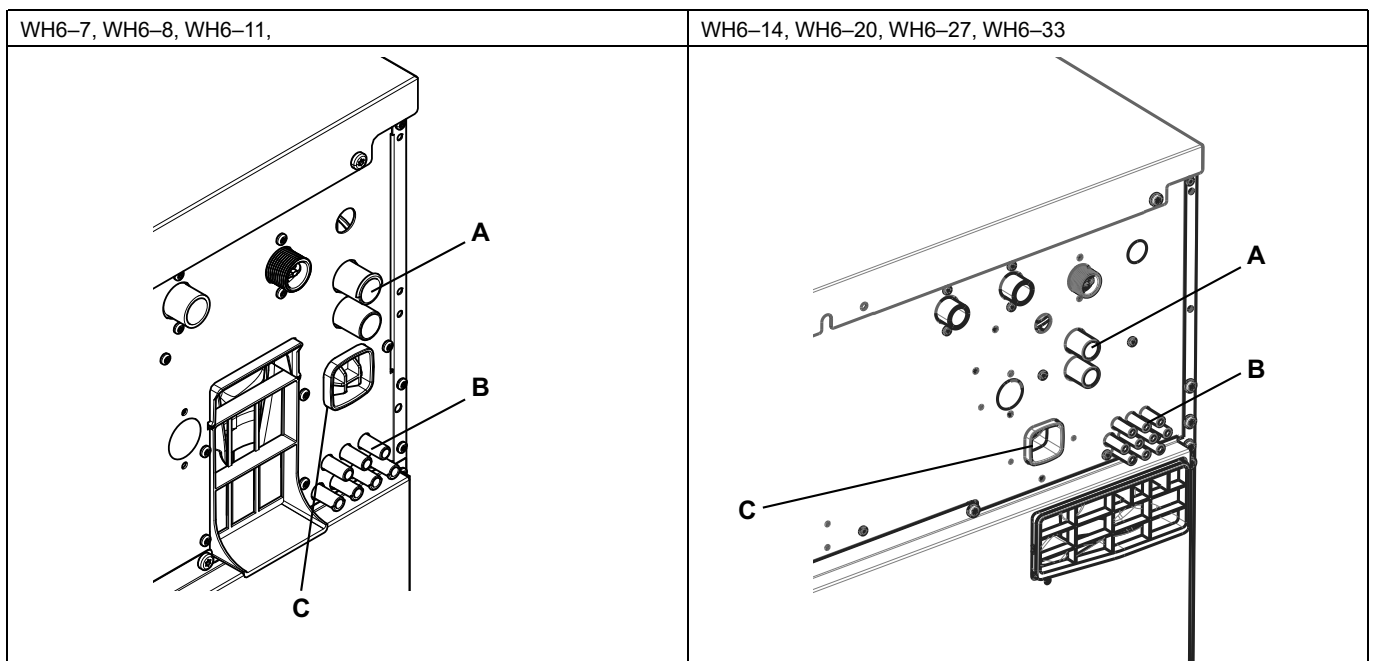

Always connect hoses on connections (A) with a hose clamp.

For connections (B); if the hoses are made of a soft material such as silicone or similar, use a cable tie to fasten the hose on the connection. If the hoses are made of a hard material, it is not recommended to make the connection tighter by using a cable tie.

#### Note!

**Equipment for external dosing must only be connected to work on pump pressure and not on network pressure.**

## 8 Drain connection

Connect a 75 mm (50 mm for models WH6–7-WH6–11) pipe or rubber hose to the machine's drain pipe, ensuring a downward flow from the machine. Avoid sharp bends which may prevent proper draining.

The machine may drain in to a drainage through or into a closed drain system. In either case, be sure to comply with all applicable national and local plumbing code provisions.

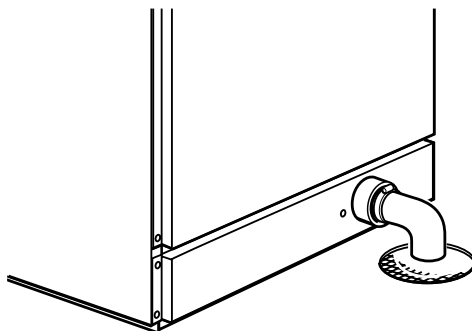

fig.5330

### Drain pump (for models WH6–7, WH6–8, WH6–11)

The drainage pipe should be located over a floor drain, drainage channel or the like.

The highest part of the drain hose shall be positioned according to the figure.

Make sure there is no kinks in the hose.

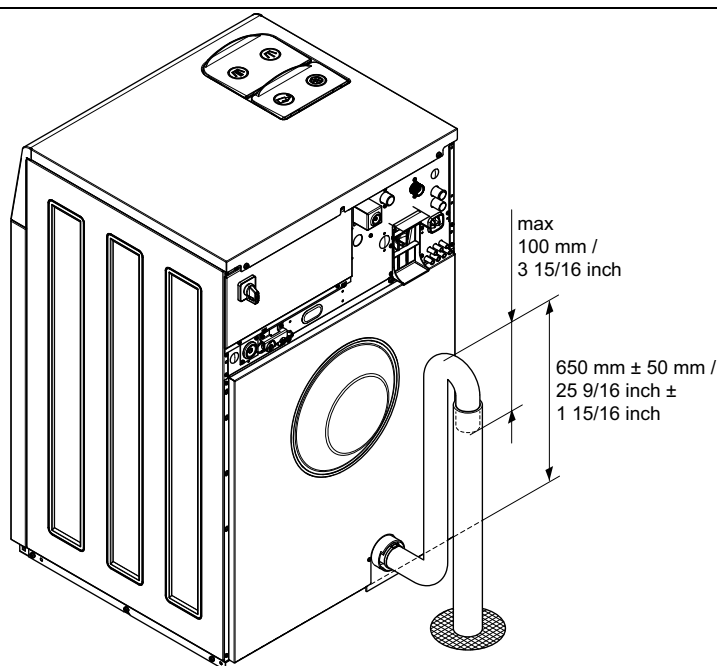

fig.X02458

## 9 Electrical connection

### 9.1 Electrical installation



The electrical installation may only be carried out by qualified personnel.



Machines with frequency-controlled motors can be incompatible with certain types of earth leakage circuit breaker. It is important to know that the machines are designed to provide a high level of personal safety, which is why items of external equipment such as earth leakage circuit breakers are not necessary but is recommended. If you still want to connect your machine across an earth leakage circuit breaker, please remember the following:

- contact a skilled, authorised installation company to ensure that the appropriate type of breaker is chosen and that the dimensioning is correct
- for maximum reliability, connect only one machine per earth leakage circuit breaker
- it is important that the earth wire is properly connected.

In instances where the machine is not equipped with an omni-polar switch, one must be installed beforehand.

In accordance with the wiring rules: mount a multi-pole switch prior to the machine to facilitate installation and service operations.

The connecting cable shall hang in a gentle curve.

When connecting to a terminal block, the connection cable shell must be stripped 10-11 mm. The cable area must be at least 0.5 mm<sup>2</sup> and no more than 4 mm<sup>2</sup> (AWG12/AWG20). The terminal block used is a spring loaded cage clamp.

For AU/NZ: Fixed wiring is in accordance with AS/NZS 3000.

### 9.2 Electrical connections

#### WH6-7

Electrical connections					
Heating alternative	Main voltage	Hz	Heating power kW	Total power kW	Recommended fuse A
Electric heated	220-240V 1/1N~	50/60	2.0/3.0	2.3/3.4	16/16
	220-240V 1/1N~	50/60	5.4/7.5	5.7/7.8	25/32
	220-240V 3~	50/60	2.0/3.0	2.2/3.4	10/10
	220-240V 3~	50/60	5.4/7.5	5.7/7.8	16/25
	380-415V 3N/3~	50/60	2.0/3.0	2.2/3.4	10/10
	380-415V 3N/3~	50/60	5.4/7.5	5.7/7.8	10/16
	440V 3~	50/60	5.4/7.5	5.7/7.8	10/16
	480V 3~	60	5.4/7.5	5.7/7.8	10/16
Non heated/Steam heated	208-240V 1/1N~	50/60	1	1.0	10
	380-480V 1~ <sup>2</sup>	50/60	1	1.0	10

1. Total power and recommended fuse does not depend on the heating power in those cases.

2. Prepared for 3~

**WH6-8**

<b>Electrical connections</b>					
Heating alternative	Main voltage	Hz	Heating power kW	Total power kW	Recommended fuse A
Electric heated	220-240V 1/1N~	50/60	2.0/3.0	2.3/3.4	16/16
	220-240V 1/1N~	50/60	5.4/7.5	5.7/7.8	25/32
	220-240V 3~	50/60	2.0/3.0	2.2/3.4	10/10
	220-240V 3~	50/60	5.4/7.5	5.7/7.8	16/25
	380-415V 3N/3~	50/60	2.0/3.0	2.2/3.4	10/10
	380-415V 3N/3~	50/60	5.4/7.5	5.7/7.8	10/16
	440V 3~	50/60	5.4/7.5	5.7/7.8	10/16
Non heated/Steam heated	480V 3~	60	5.4/7.5	5.7/7.8	10/16
	208-240V 1/1N~	50/60	<sup>1</sup>	1.0	10
	380-480V 1~ <sup>2</sup>	50/60	<sup>1</sup>	1.0	10

1. Total power and recommended fuse does not depend on the heating power in those cases.
2. Prepared for 3~

**WH6-11**

<b>Electrical connections</b>					
Heating alternative	Main voltage	Hz	Heating power kW	Total power kW	Recommended fuse A
Electric heated	220-240V 1/1N~	50/60	3.0/7.5/10.0	3.1/7.6/10.1	16/32/50
	220-240V 3~	50/60	3.0/7.5/10.0	3.1/7.6/10.1	10/20/25
	380-415V 3/3N~	50/60	3.0/7.5/10.0	3.1/7.6/10.1	10/16/16
	440V 3~	50/60	7.5/10.0	7.6/10.1	16
	480V 3~	60	10.0	10.1	16
Non heated/Steam heated	208-240V 1/1N~	50/60	<sup>1</sup>	1.1	10
	380-480V 1~ <sup>2</sup>	50/60	<sup>1</sup>	1.1	10

1. Total power and recommended fuse does not depend on the heating power in those cases.
2. Prepared for 3~

**WH6-14**

<b>Electrical connections</b>					
Heating alternative	Main voltage	Hz	Heating power kW	Total power kW	Recommended fuse A
Electric heated	220-240V 1/1N~	50/60	4.8/13.0	5.2/13.4	25/63
	220-240V 3~	50/60	4.8/13.0	5.2/13.4	16/35
	380-415V 3N/3~	50/60	4.8/13.0	5.2/13.4	10/20
	440V 3~	50/60	13.0	13.4	20
	480V 3~	60	13.0	13.4	20
Non heated/Steam heated	208-240V 1/1N~	50/60	<sup>1</sup>	1.2	10
	380-480V 1~ <sup>2</sup>	50/60	<sup>1</sup>	1.2	10

1. Total power and recommended fuse does not depend on the heating power in those cases.
2. Prepared for 3~

**WH6-20**

<b>Electrical connections</b>					
Heating alternative	Main voltage	Hz	Heating power kW	Total power kW	Recommended fuse A
Electric heated	220-240V 3~	50/60	18.0	18.5	50
	380-415V 3N/3~	50/60	18.0	18.5	32
	440V 3~	50/60	18.0	18.5	25
	480V 3~	60	18.0	18.5	25
Non heated/Steam heated	208-240V 1/1N~	50/60	<sup>1</sup>	2.5	10
	380-480V 1~ <sup>2</sup>	50/60	<sup>1</sup>	2.5	10

1. Total power and recommended fuse does not depend on the heating power in those cases.
2. Prepared for 3~

**WH6-27**

Electrical connections					
Heating alternative	Main voltage	Hz	Heating power kW	Total power kW	Recommended fuse A
Electric heated	220-230V 3~	50/60	19.1	19.8	63
	220-240V 3~	50/60	19.8/23.0	20.5/23.7	63/63
	380-400V 3N/3~	50/60	19.1	19.8	32
	380-415V 3N/3~	50/60	19.8/23.0	20.5/23.7	32/35
	440V 3~	50/60	21.0/23.0	21.7/23.7	32/32
	480V 3~	60	22.8/23.0	23.5/23.7	32/32
Non heated/Steam heated	208-240V 1/1N~	50/60	<sup>1</sup>	2.6	16
	380-480V 1~ <sup>2</sup>	50/60	<sup>1</sup>	2.6	10

1. Total power and recommended fuse does not depend on the heating power in those cases.
2. Prepared for 3~

**WH6-33**

Electrical connections					
Heating alternative	Main voltage	Hz	Heating power kW	Total power kW	Recommended fuse A
Electric heated	220-230V 3~	50/60	19.1	19.4	50
	220-240V 3~	50/60	19.8/23.0	20.2/23.3	50/63
	380-400V 3N/3~	50/60	19.1	19.6	32
	380-415V 3N/3~	50/60	19.8/23.0	20.1/23.3	32/35
	380V 3N~	50	9.5	9.9	16
	440V 3~	50/60	21.0/23.0	21.4/23.3	32/32
	480V 3~	60	22.8/23.0	23.2/23.4	32/32
Non heated/Steam heated	208-240V 1/1N~	50/60	<sup>1</sup>	3.5	16
	380-480V 1~ <sup>2</sup>	50/60	<sup>1</sup>	3.5	10

1. Total power and recommended fuse does not depend on the heating power in those cases.
2. Prepared for 3~

### 9.3 Machine connection with ferrite

#### 9.3.1 WH6-14CV, WH6-20CV, WH6-27CV, WH6-33CV

To obtain approved level of EMC, it is mandatory to use the ferrite which is enclosed with above listed models. (Note that this is only valid for those models).

Before connecting to the machine, the protective earth (PE) wire shall be wrapped around the ferrite.

Prepare the power cord by making sure the protective earth (PE) wire is longer than the other wires according to the table.

Wire size	L	x times through
AWG14 or 2.5 mm <sup>2</sup>	230 mm	x 4
AWG12 or 4 mm <sup>2</sup>	250 mm	x 4
AWG10 or 6 mm <sup>2</sup>	270 mm	x 4
AWG8 or 10 mm <sup>2</sup>	290 mm	x 4
AWG6 or 16 mm <sup>2</sup>	330 mm	x 4
AWG4 or 25 mm <sup>2</sup>	490 mm	x 4

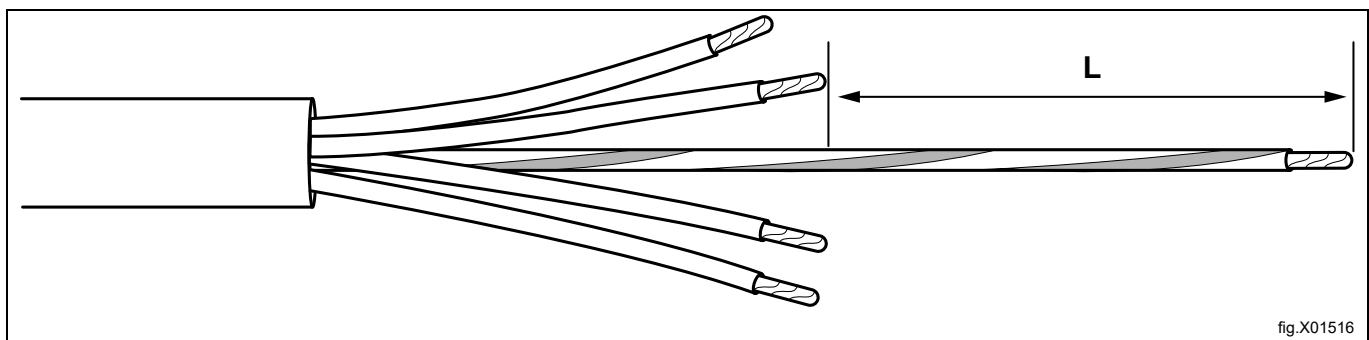

fig.X01516

When the power cord has been prepared according to the table, wrap the protective earth (PE) wire through the ferrite and then connect all wires according to the “Machine connection” section.

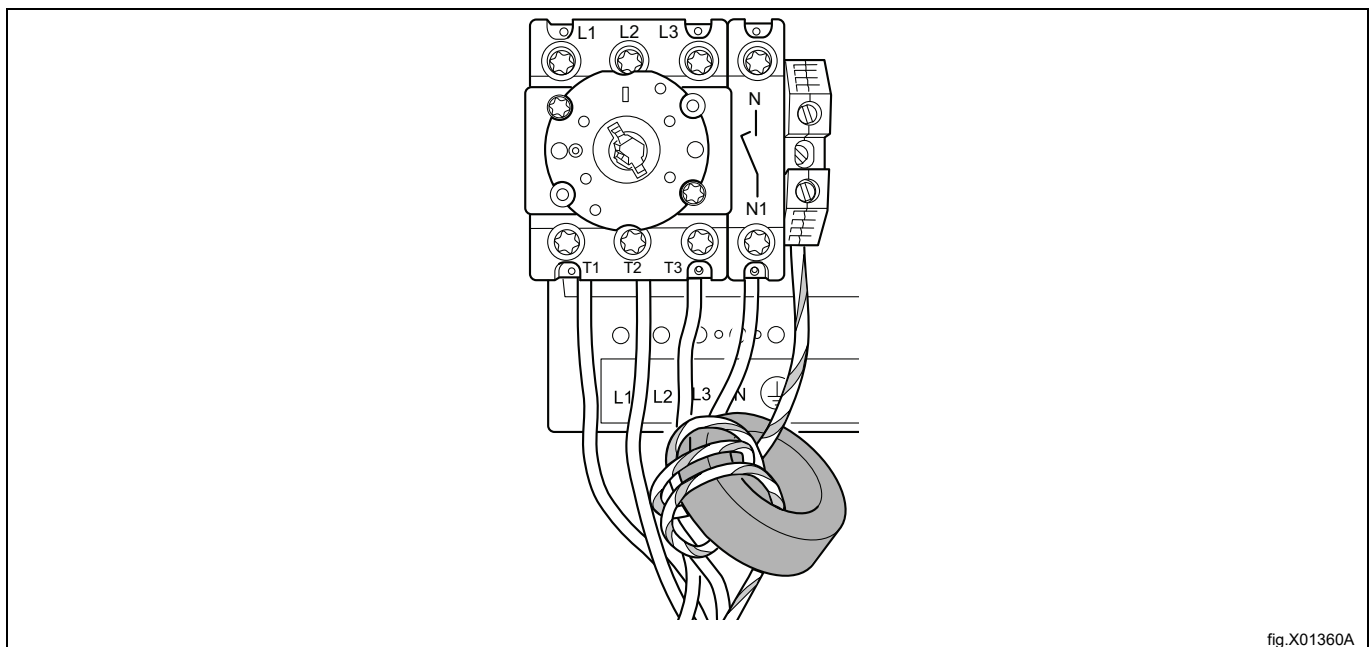
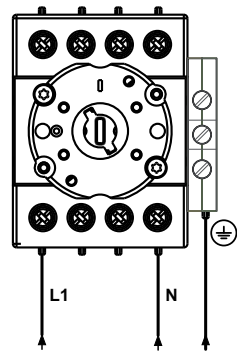
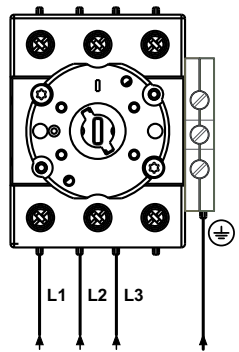
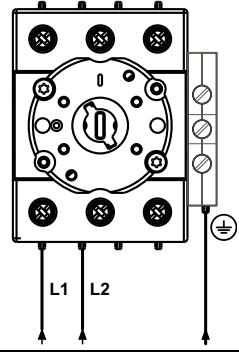
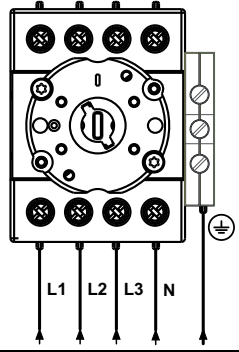
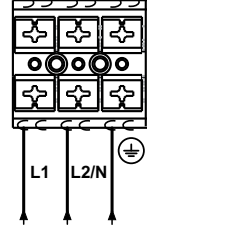
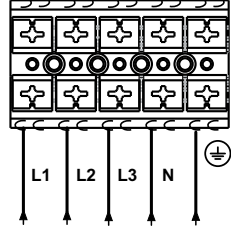

fig.X01360A

### 9.4 Machine connection

Connect the earth and other wires according to the table.

Single-phase connection		Three-phase connection	
1NAC		3AC	
1AC		3N AC	
1N/1		3N AC	

Single phase machines may be powered either by connection between a phase and neutral or by connecting between two phases.

Example:

Machines for 220-240V single phase may be powered from 380V or 400V or 415V system by connection between a phase and neutral or from 220V or 230V or 240V system by connection between two phases.

### 9.5 Connector with termination resistor

To maintain stability of internal data bus, it is mandatory to use the connector with termination resistor which is enclosed with all machines.

Connect the connector with termination resistor to connection B at the rear of the machine.

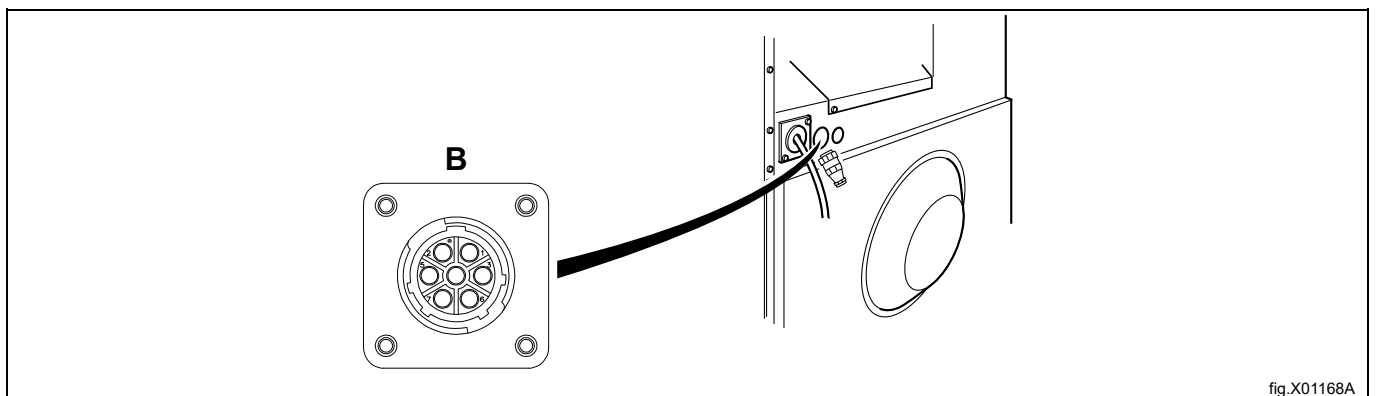

fig.X01168A

## 9.6 Connection of external functions

### 9.6.1 Outputs

Depending on machine configuration, the outputs are configured according to the following table:

Connection	Config. 22A	Config. 22B
Terminal 12	Steam valve (if dual heating)	Steam valve (if dual heating)
Terminal 13	n/a	Liquid 1
Terminal 14	n/a	Liquid 2
Terminal 15	n/a	Liquid 3
Terminal 16	n/a	Liquid 4
Terminal 18	Program run	Program run

If the external power (e.g. 24V DC) is being used, connect the power supply to terminal 9 and 10.

If the internal power (230V from the machine) is being used, connect a jumper from terminal 1 (N) to 9 and a jumper from terminal 2 (L) to 10. Max load to the outputs is 0.5A.

#### Note!

On machines with Dual heating, the Steam valve is controlled by internal power (230V), which means that the terminals 9 and 10 are already occupied. Since all outputs share the power source, the rest of the outputs will refer to internal power as well (please refer to chapter “Dual heating and Trigger signals for dosing system without saving”).

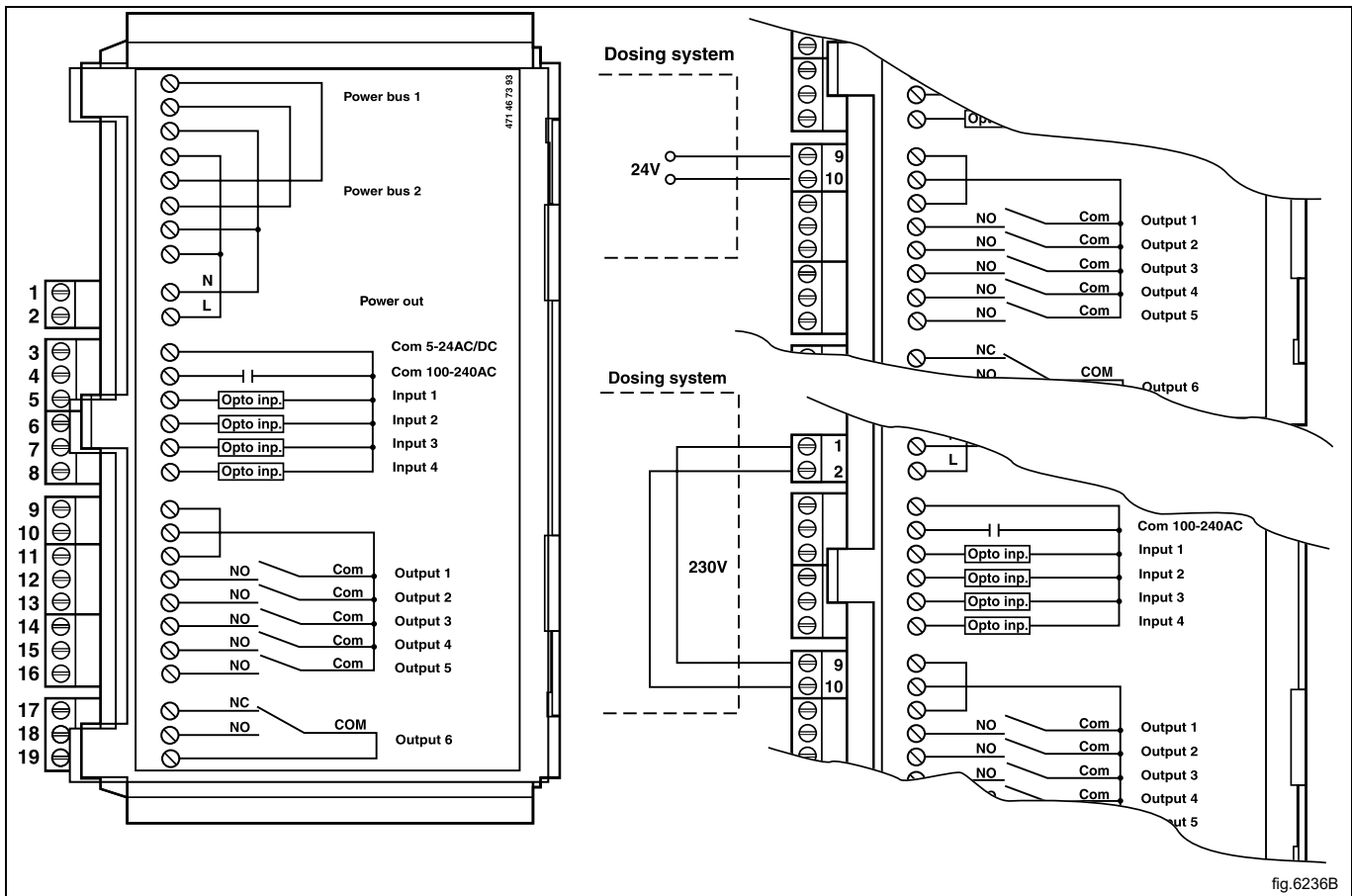

### 9.6.2 Inputs

Depending on machine configuration, the inputs are configured according to the following table:

Connection	Config. 22A	Config. 22B
Terminal 5	Enable start	Enable start
Terminal 6	Remote start /stop	Remote start /stop
Terminal 7	Coin 1	Coin 1
Terminal 8	Pause	Pause

The signal level for the inputs can be either 5-24V DC/AC or 100- 240V AC.

For 5-24V, connect the signal reference to terminal 3 and for 100-240V to terminal 4. The potentials on the inputs cannot be mixed!

The figure shows an example of connecting a 24V pause signal. The program will pause for as long as the pause signal remains active (high), e.g. while waiting for central dosing system to be ready.

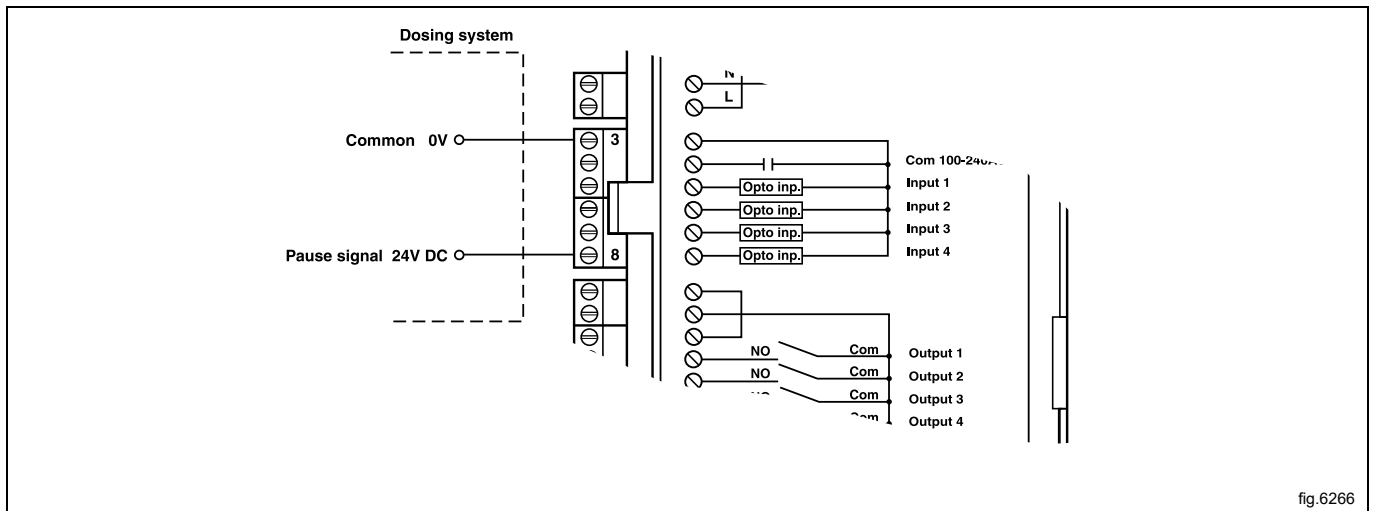

fig.6266

### 9.7 Functions for I/O-boards

The electrical schematic can be one of the following:

#### 9.7.1 Enable start (22A, 22B)

This signal can be used to permit the start of the program when the machine is in standby.

Once permission to start has been granted, the signal from the central payment or the booking system must remain active (high) until the machine starts.

To receive the feedback signal from the machine, 230V or 24V must be connected to terminal 19. The feedback signal on terminal 18 will remain active (high) during entire program.

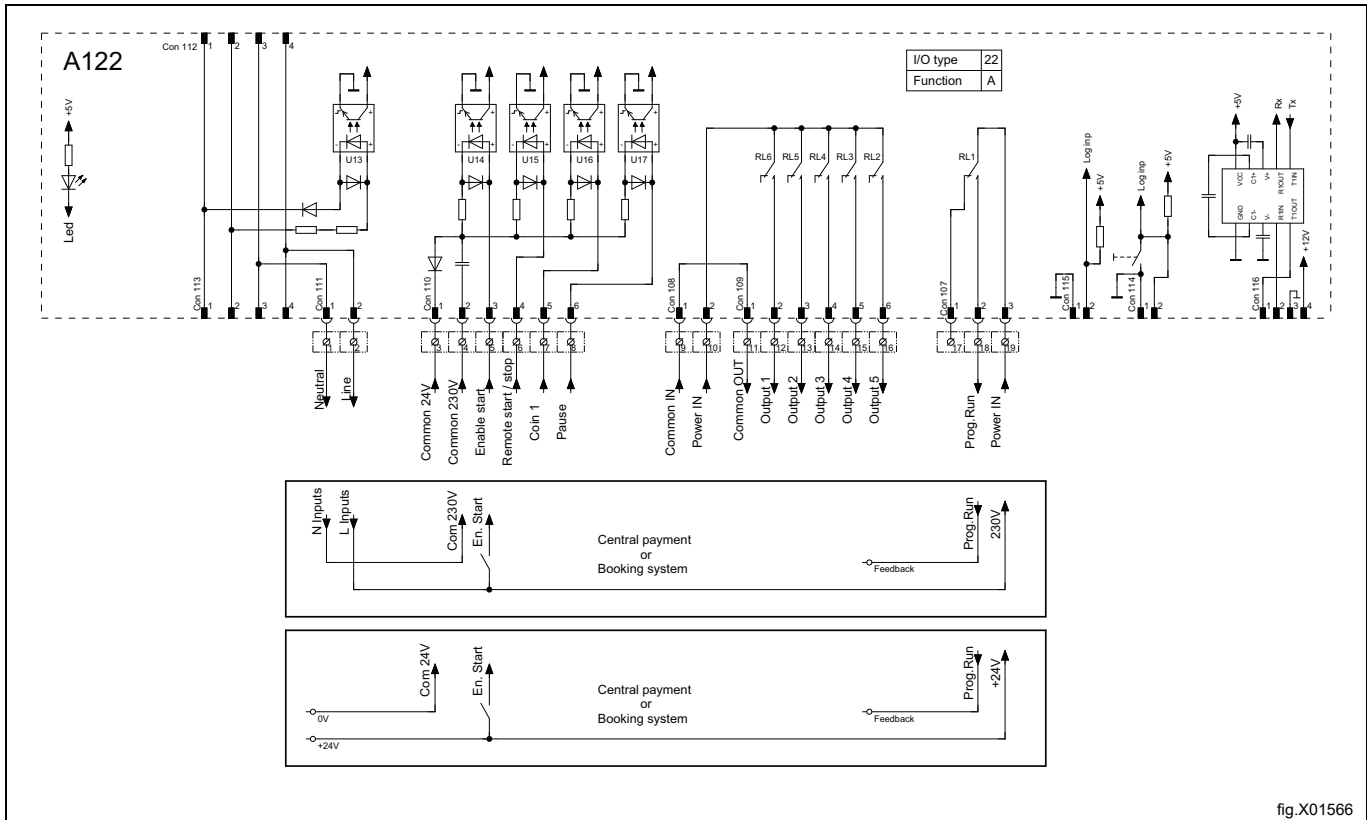

fig.X01566

### 9.7.2 Remote start/stop (22A, 22B)

This signal can be used to start the program when the machine is in standby, to pause the cycle when running and to continue the cycle when paused.

The central payment system must provide a pulse to start the program.

To receive the feedback signal from the machine, 230V or 24V must be connected to terminal 19. The feedback signal on terminal 18 will remain active (high) during entire program.

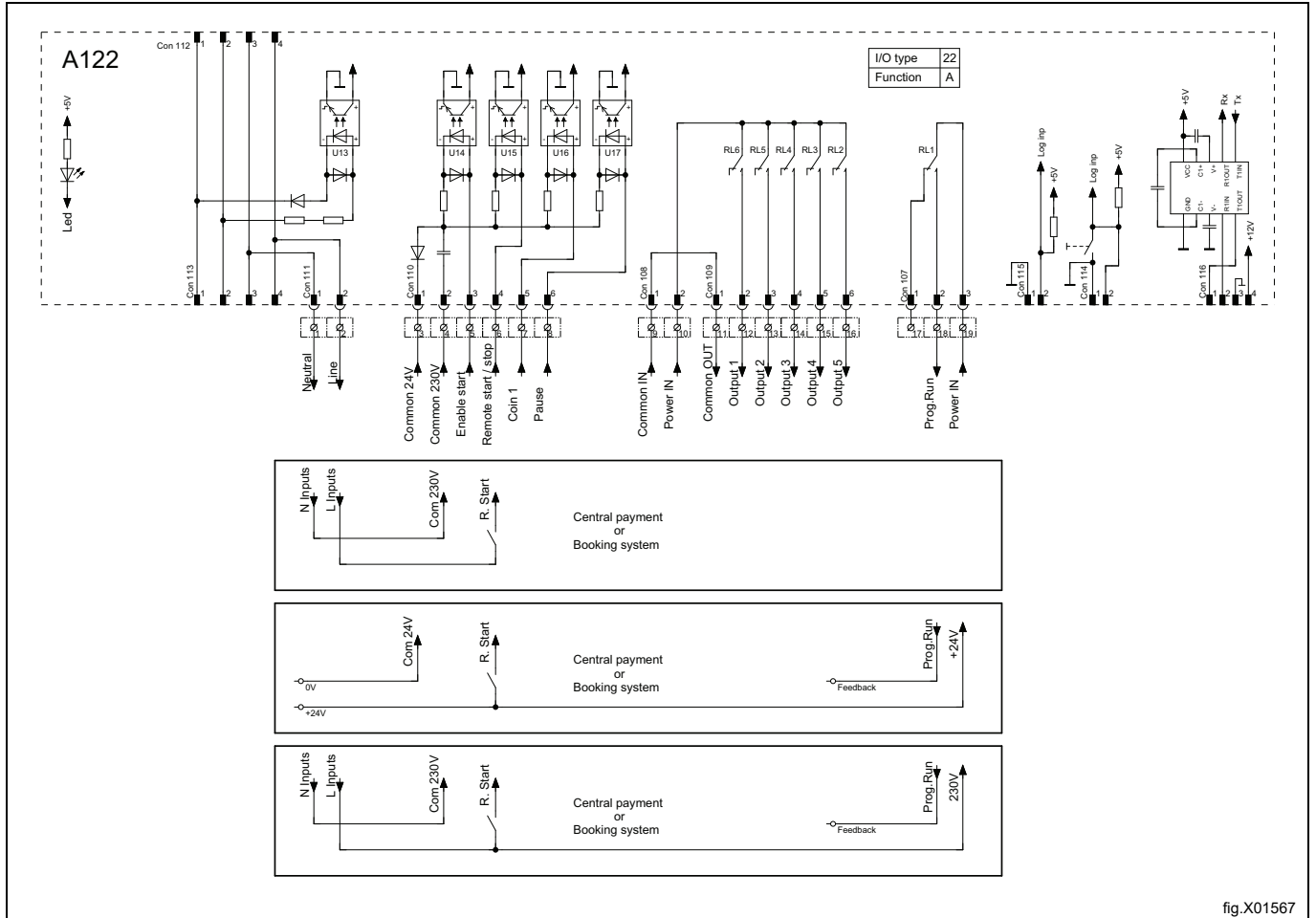

### 9.7.3 External coin meter/Central payment (22A, 22B)

The signal received from external coin meter must be a pulse between 300–3000 ms (500 ms is recommended) with a minimum pause of 300 ms (500 ms is recommended) between two pulses.

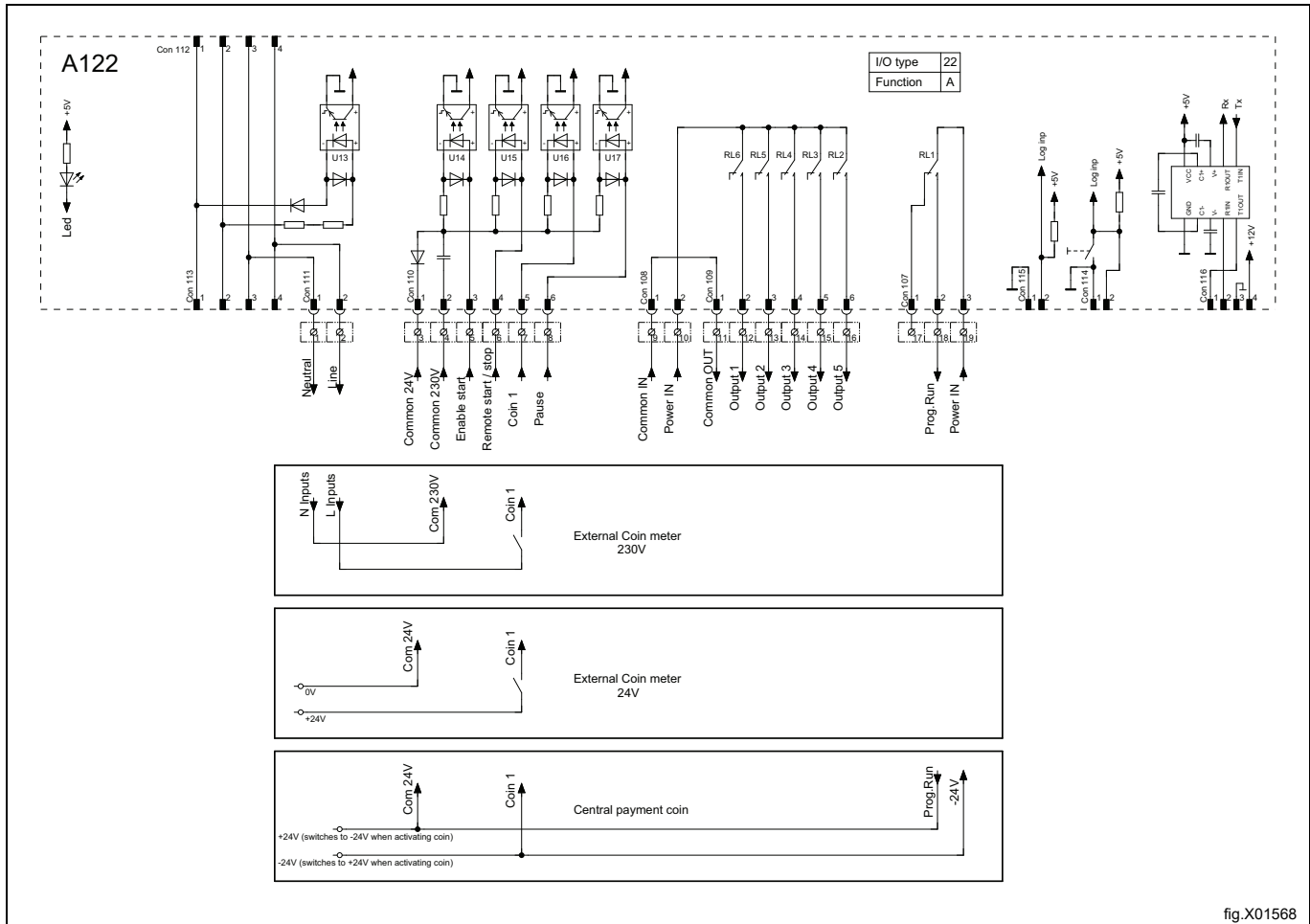

### 9.7.4 Pause (22A, 22B)

This signal can be used to pause the program when running.

When the signal is activated, the program will pause for as long as the signal remains active (high), e.g. while waiting for central dosing system to be ready.

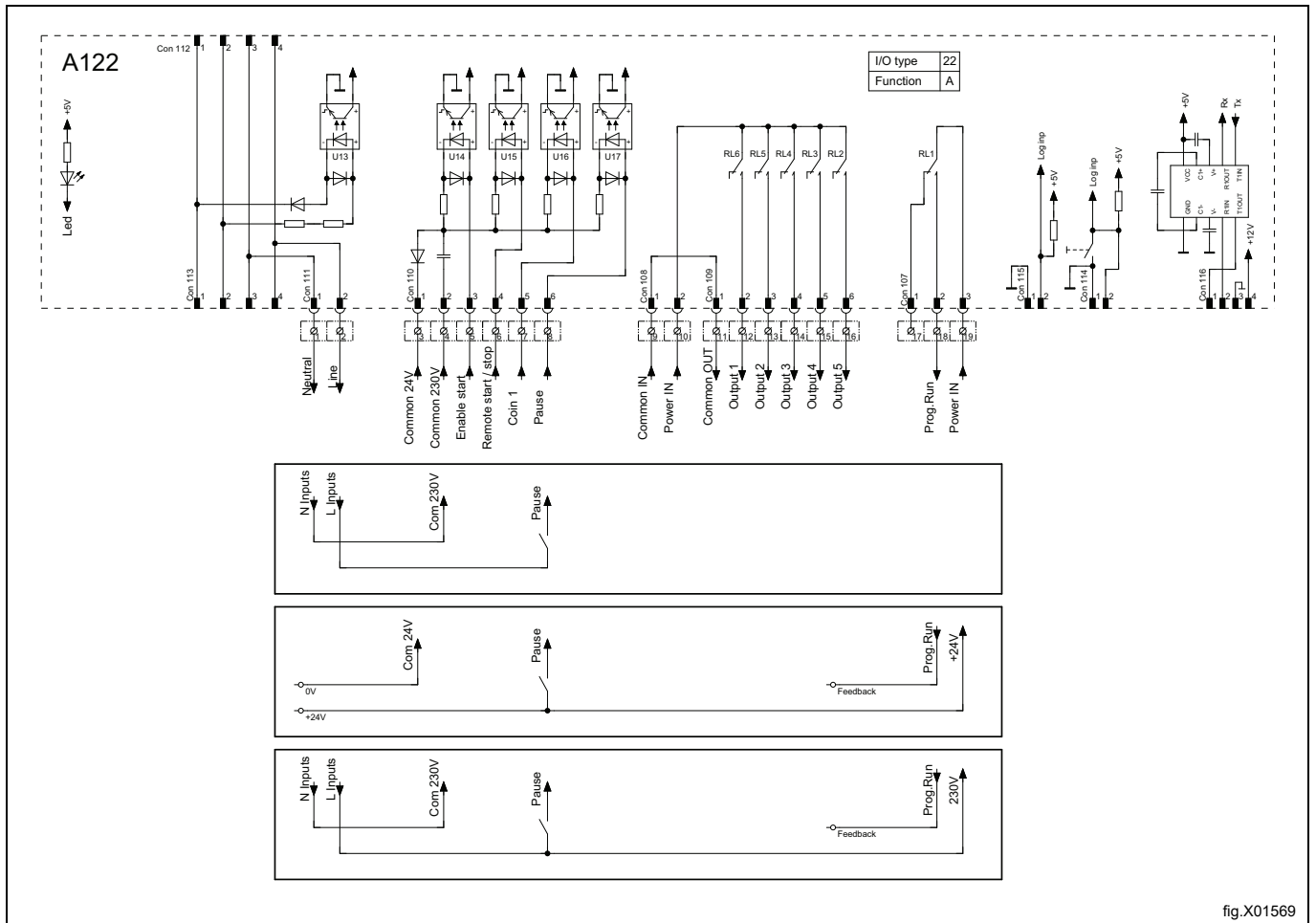

### 9.7.5 Dual heating (22A, 22B)

This output is used to activate the steam valve on machines made for dual heating.

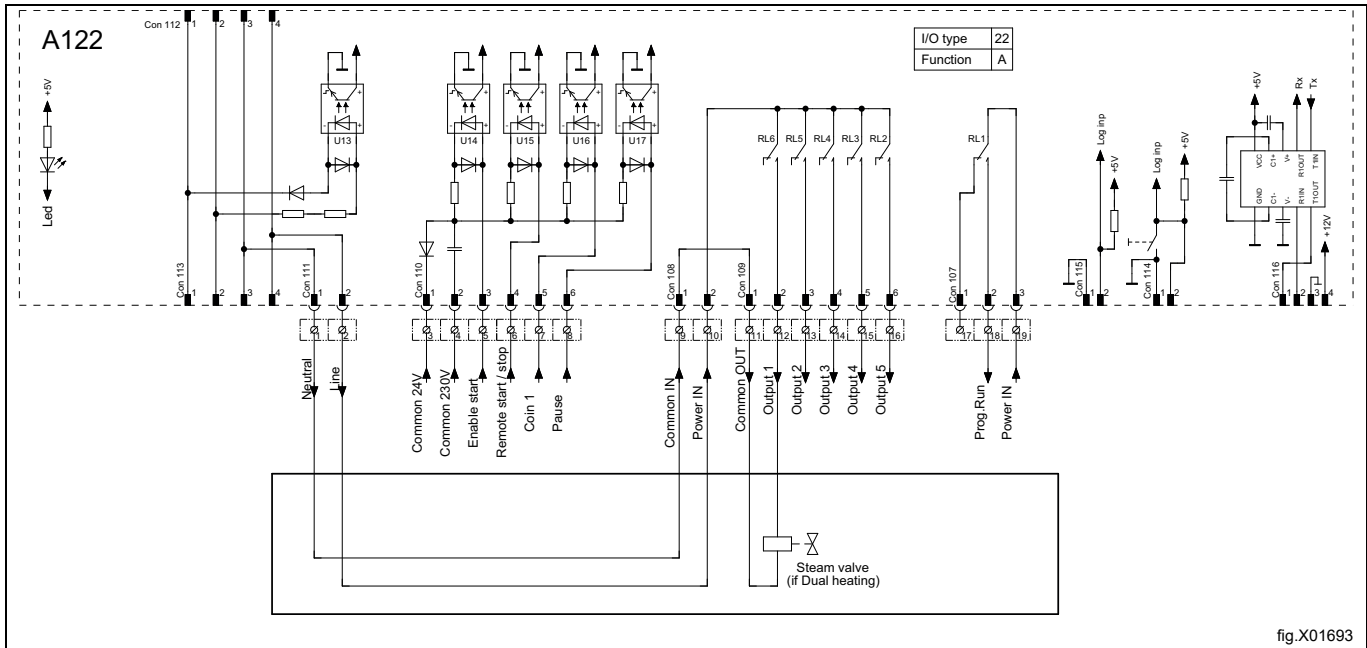
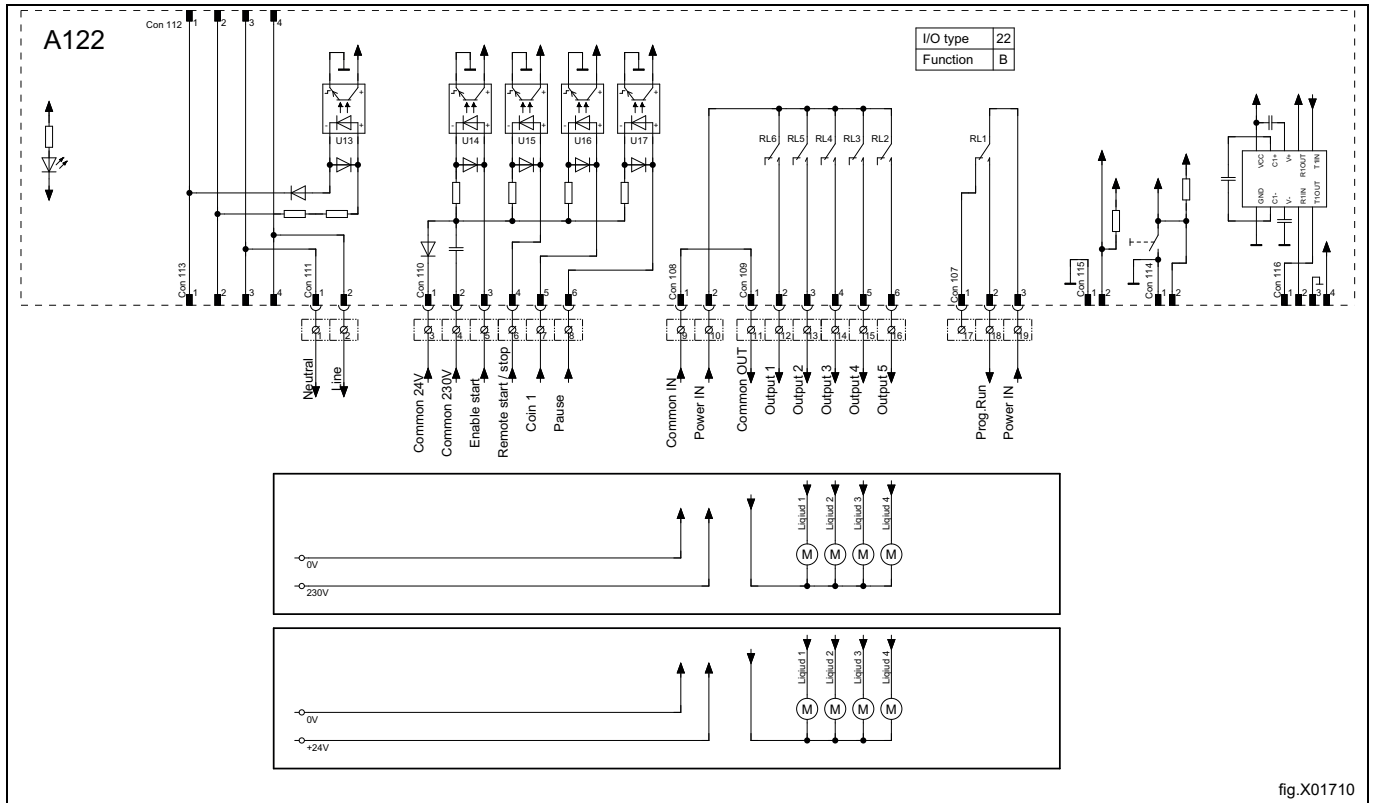

fig.X01693

### 9.7.6 Trigger signals for dosing system without saving (22B)

The following outputs can be used as trigger signals for dosing system or for activation of external pumps.



### 9.7.7 Dual heating and Trigger signals for dosing system without saving (22B)

On machines with Dual heating, the trigger signals refer to the internal power (230V). In this case, no other power sources are allowed.

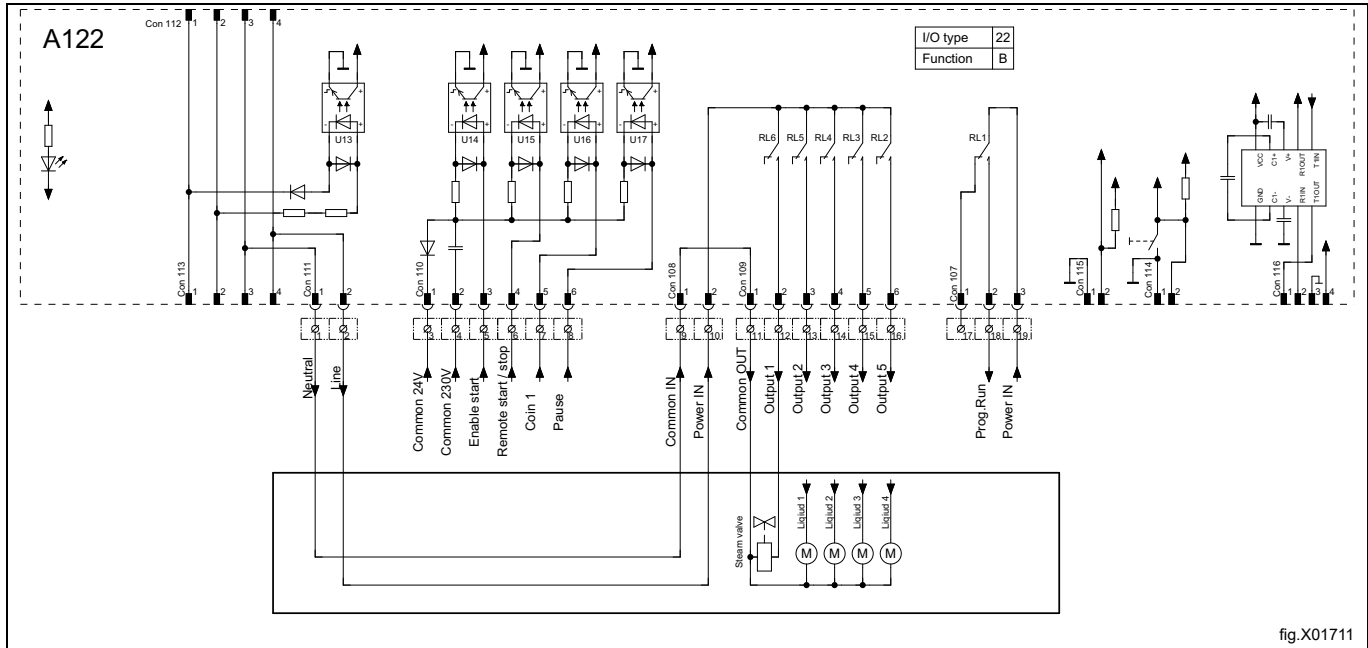

## 9.8 Converting heating elements

### 9.8.1 WH6–7, WH6–8 and WH6–11 can be converted from 400-415V 3AC to 230-240V 1AC with reduced power

Disconnect the power to the machine.

Demount the front panel and remove the cover to the heating elements.

Remove the blue cables.

Move cables 357/BN on E1 and 358/GY on E3 from the red to the white terminals on each element according to the figure.

Remount the cover to the heating elements and remount the cover panel.

Demount the cover panel to the contactors. Shift position on cables 357/BN and 358/GY on heating contactor K21 according to the figure.

Move cables L3 to N according to the figure.

Remount the cover panel to the contactors.

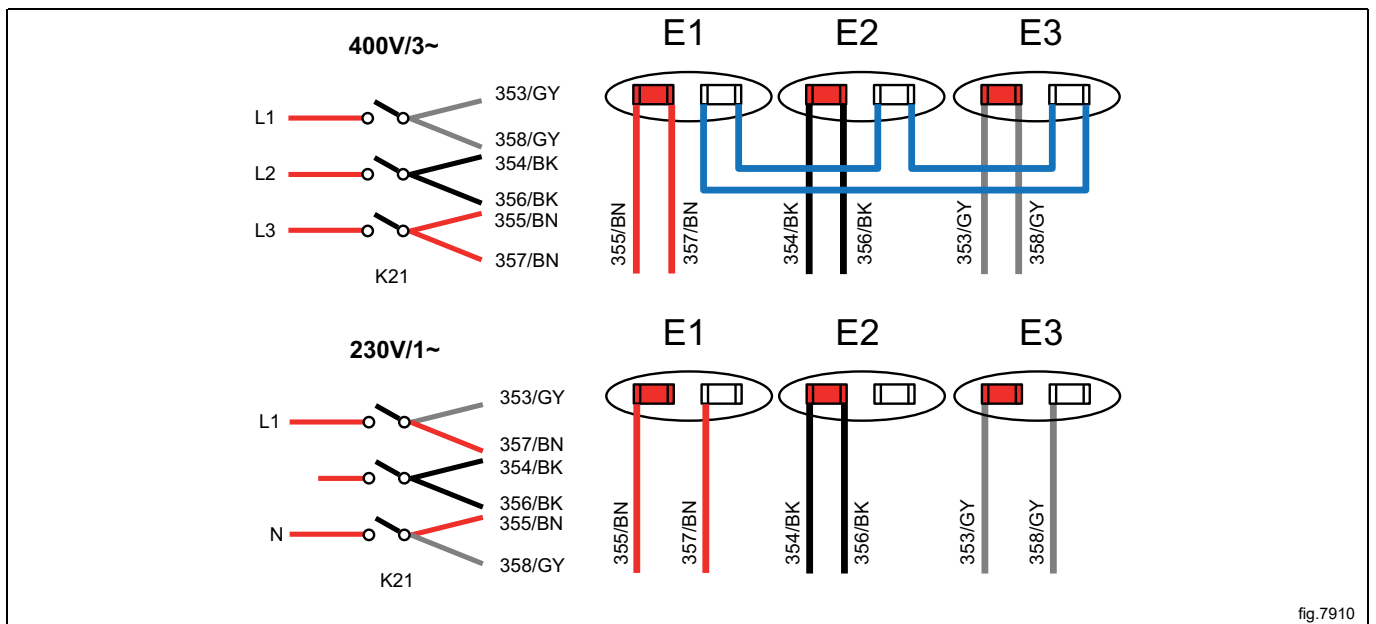

fig.7910

Connect the power to the machine.

Check that all terminals and wires are secure and test run the machine on a short program with 60°C to ensure that it does heat up.

### 9.8.2 WH6-14 can be converted from 380-415V 3N AC to 220-240V 1N AC with reduced power

Disconnect the power to the machine.

Demount the cover panel to the electrical connections.

Remove the cables that are connected to K21:2 and K22:6. Move the remaining cables from L2 and L3 to L1 or N according to the figure.

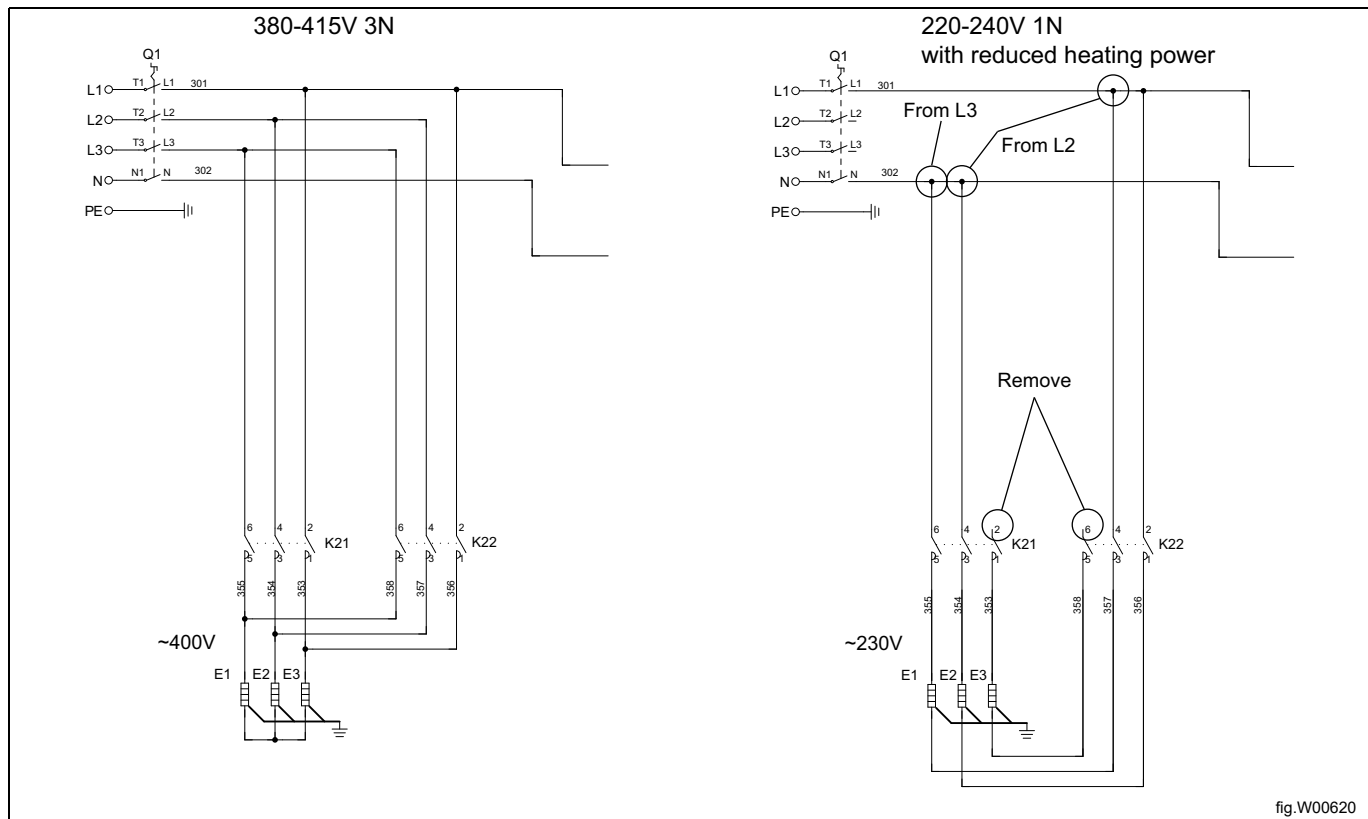

Remount the cover panel to the electrical connections.

Connect the power to the machine.

Check that all terminals and wires are secure and test run the machine on a short program with 60°C to ensure that it does heat up.

### 10 Steam connection

Inlet pipes connected to the machine must be equipped with a manual shut-off valve to facilitate installation and servicing. The connection hose must be of type ISO/1307- 1983 or equivalent.

Connection size at filter: DN 15 (BSP 1/2").

Demount the top panel (A). Demount the casing (B).

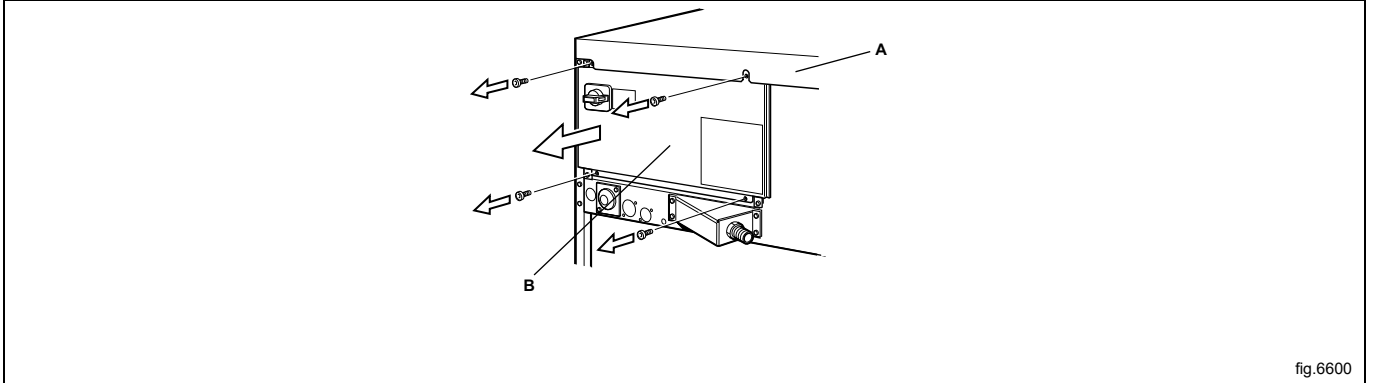

fig.6600

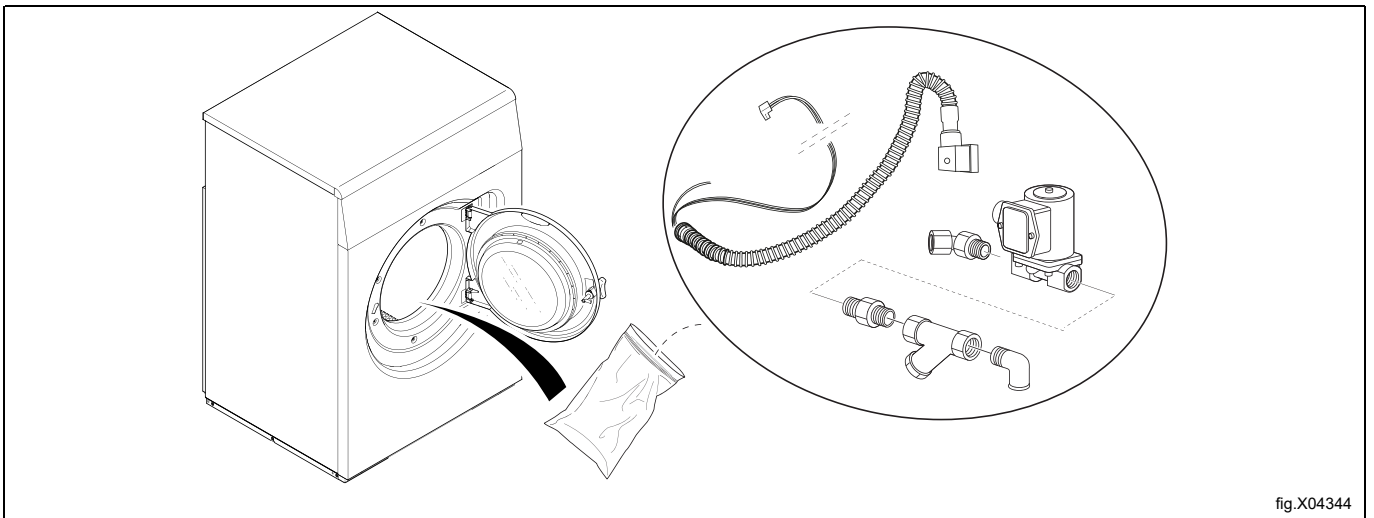

fig.X04344

Mount the nipple to the steam valve. Mount the steam valve on the machine. Mount nipple, strainer and elbow. Note the direction of the strainer. Mount steam hose to the elbow. Check that there are no sharp angles or bends on the connected steam hose.

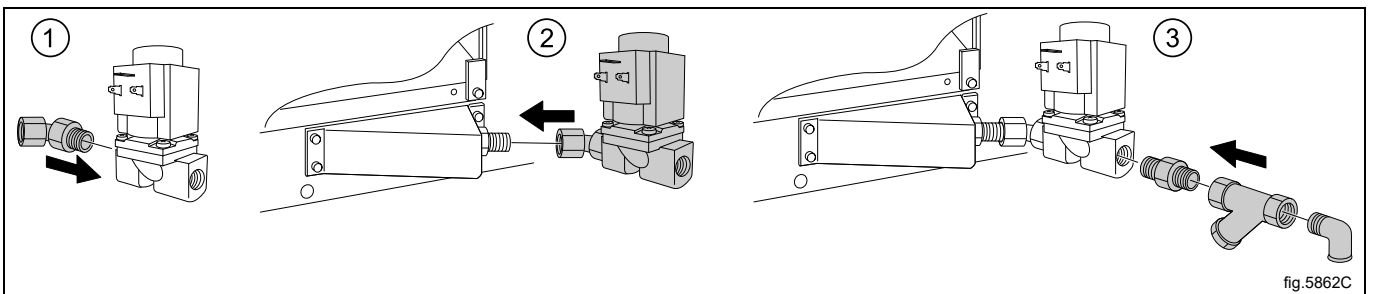
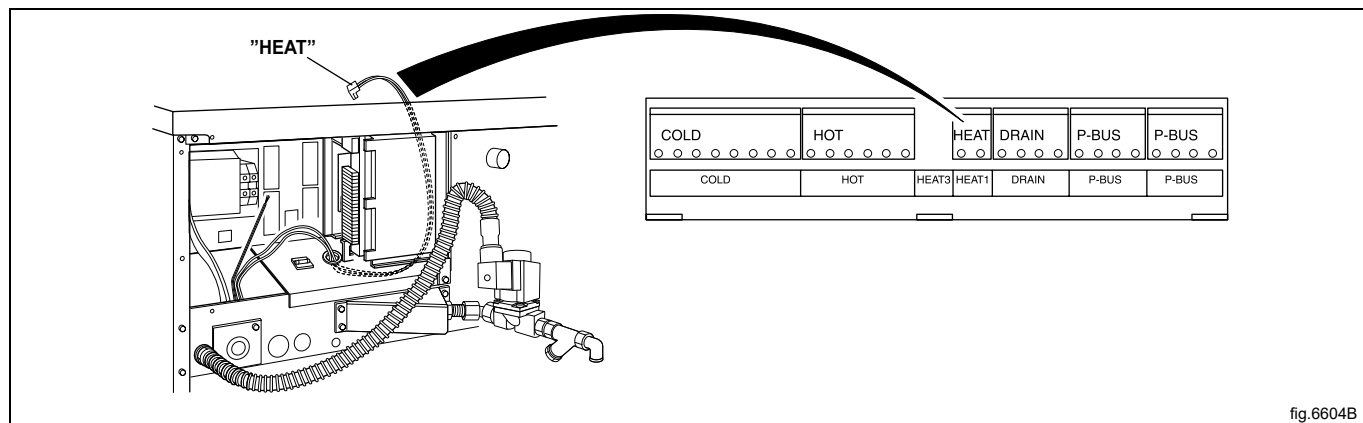

fig.5862C

Mount the hose with wires between steam valve and machine. Connect the wires to the steam valve. Connect ground cable to the terminal ground connection. Connect the "HEAT" cable connector to the "HEAT" terminal on the I/O board.



Steam pressure required:

- minimum: 50 kPa (0.5 kp/cm<sup>2</sup>)
- maximum: 800 kPa (8 kp/cm<sup>2</sup>)
- recommended: 600 kPa (6 kp/cm<sup>2</sup>)

**Note!**

**A steam heated machine is only intended to use clean steam.**

## 11 Steam connection for dual heating (option for WH6-14, WH6-20, WH6-27, WH6-33 )

Inlet pipes connected to the machine must be equipped with a manual shut-off valve to facilitate installation and servicing. The connection hose must be of type ISO/1307- 1983 or equivalent.

Connection size at filter: DN 15 (BSP 1/2").

Demount the top panel (A). Demount the casing (B).

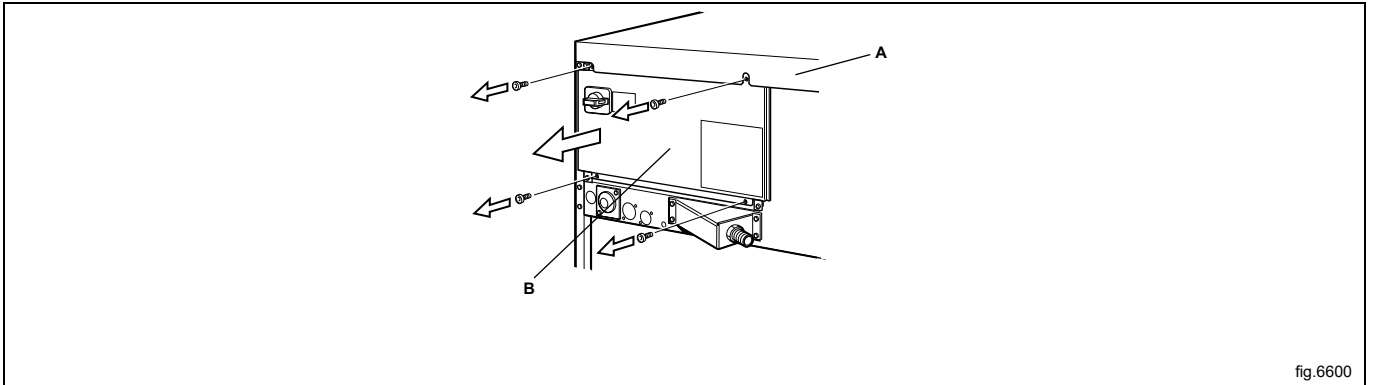

fig.6600

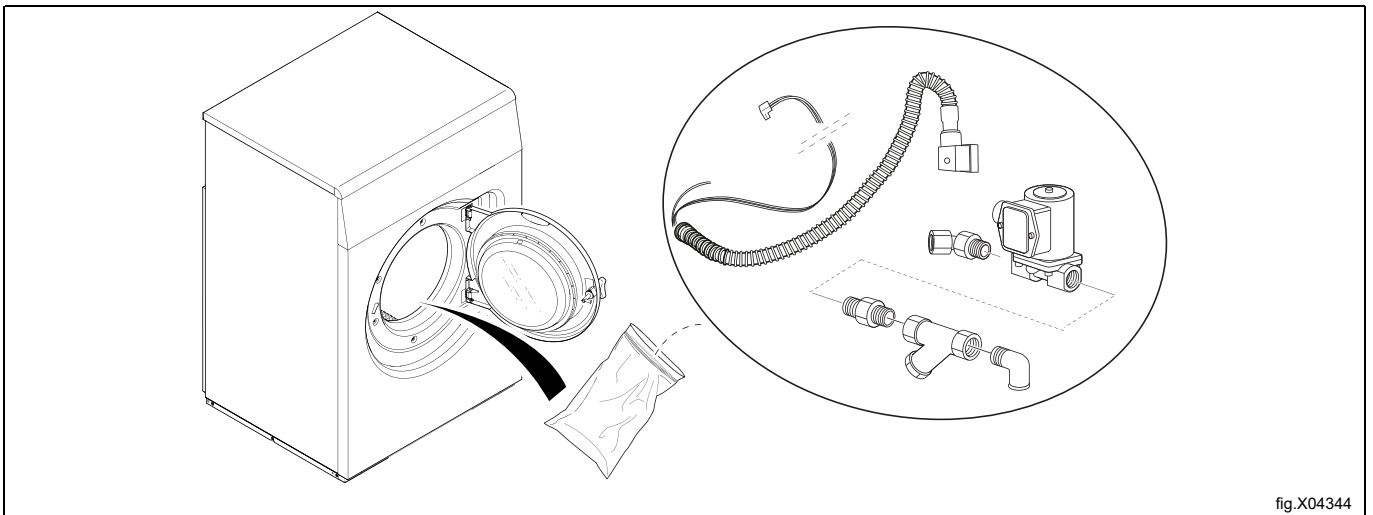

fig.X04344

Mount the nipple to the steam valve. Mount the steam valve on the machine. Mount nipple, strainer and elbow. Note the direction of the strainer. Mount steam hose to the elbow. Check that there are no sharp angles or bends on the connected steam hose.

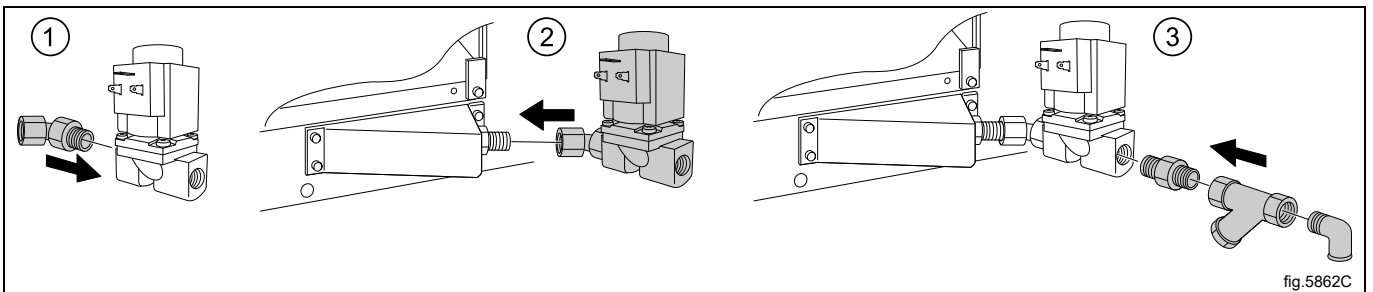

fig.5862C

Mount the hose with wires between steam valve and machine. Connect the wires to the steam valve. Connect ground cable to the terminal ground connection.

Cut the wires a few centimeters from the "HEAT-connector".

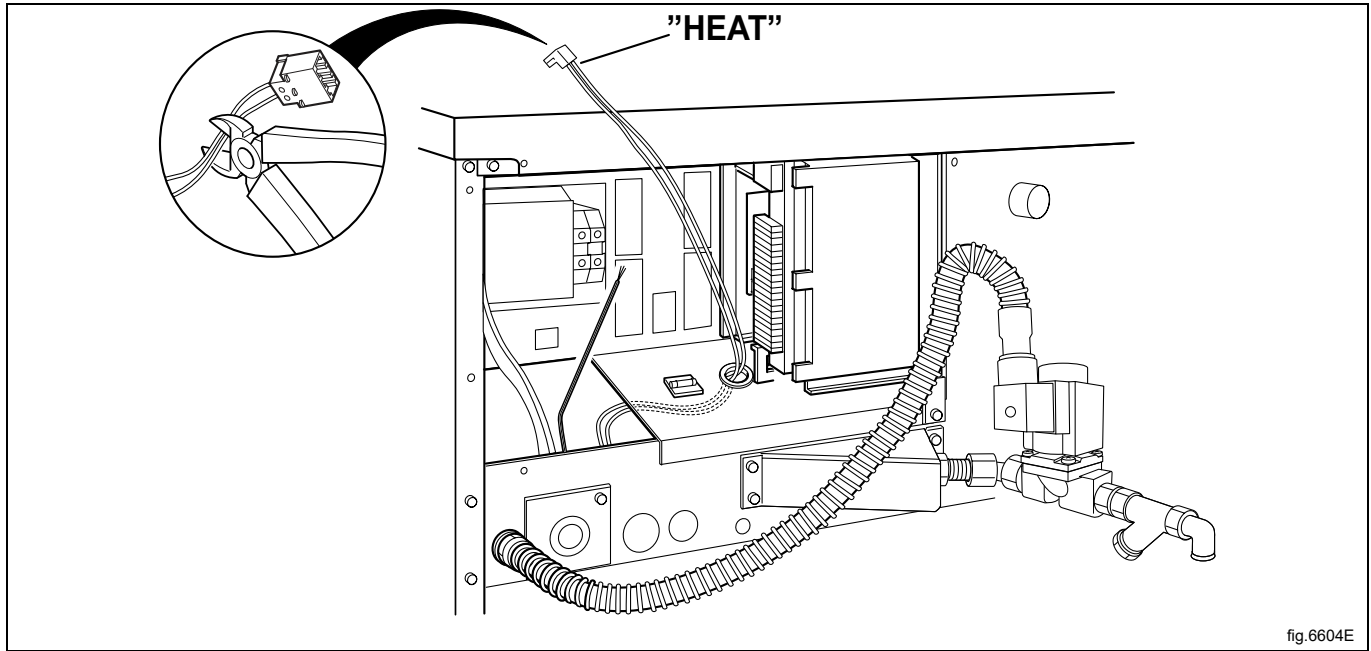

fig.6604E

Connect the cut wires to connection 11 and 12 on the I/O board.

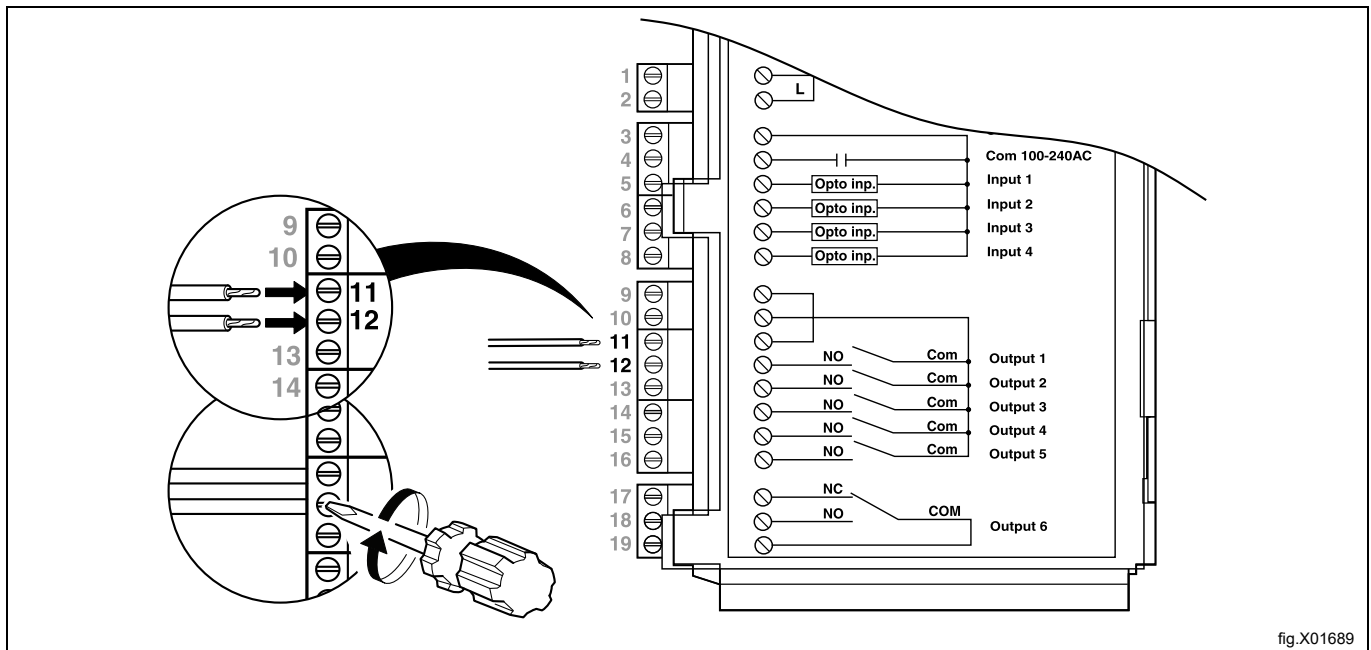
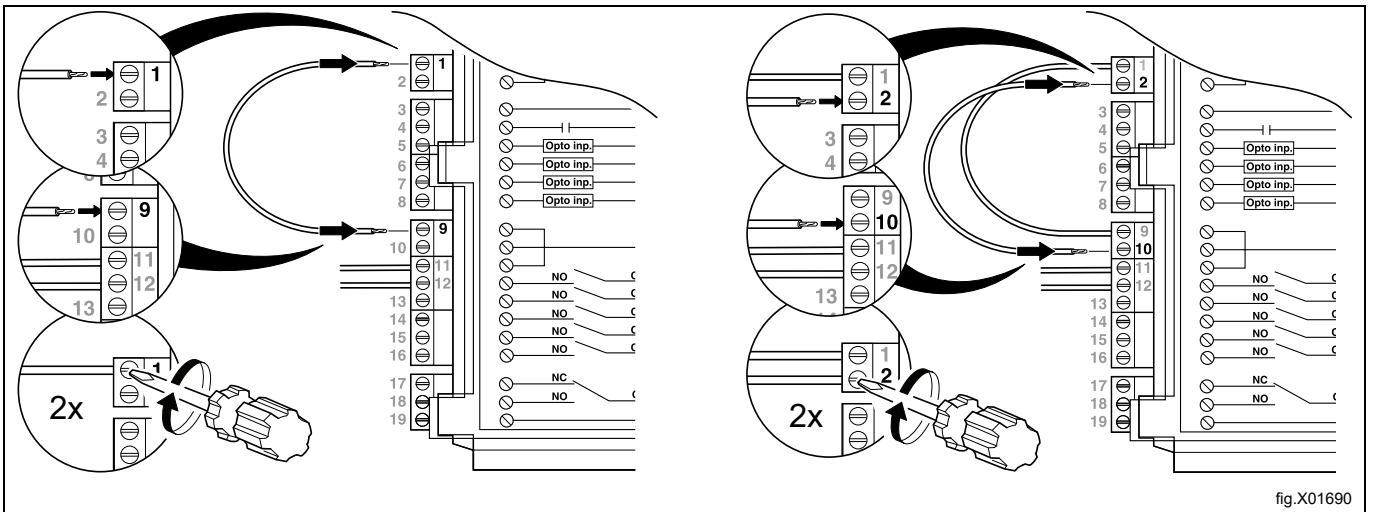

fig.X01689

Connect jumpers between connection 1 and 9 and between connection 2 and 10 on the I/O board.



Steam pressure required:

- minimum: 50 kPa (0.5 kp/cm<sup>2</sup>)
- maximum: 800 kPa (8 kp/cm<sup>2</sup>)
- recommended: 600 kPa (6 kp/cm<sup>2</sup>)

**Note!**

**A steam heated machine is only intended to use clean steam.**

## 12 Machine with level tube and test tap (option for WH6-14, WH6-20, WH6-27, WH6-33 )

Machines with this option is built for specific customers who need to see or inspect the water level inside the drum via a glass tube which is mounted on the side of the machine.

A provided test tap is prepared for the tester/inspector and it is possible to collect sample(s) of water from the drum.

- Mount the provided test tap to the left hand side of the machine. When mounting, use thread tape and then close the test tap.

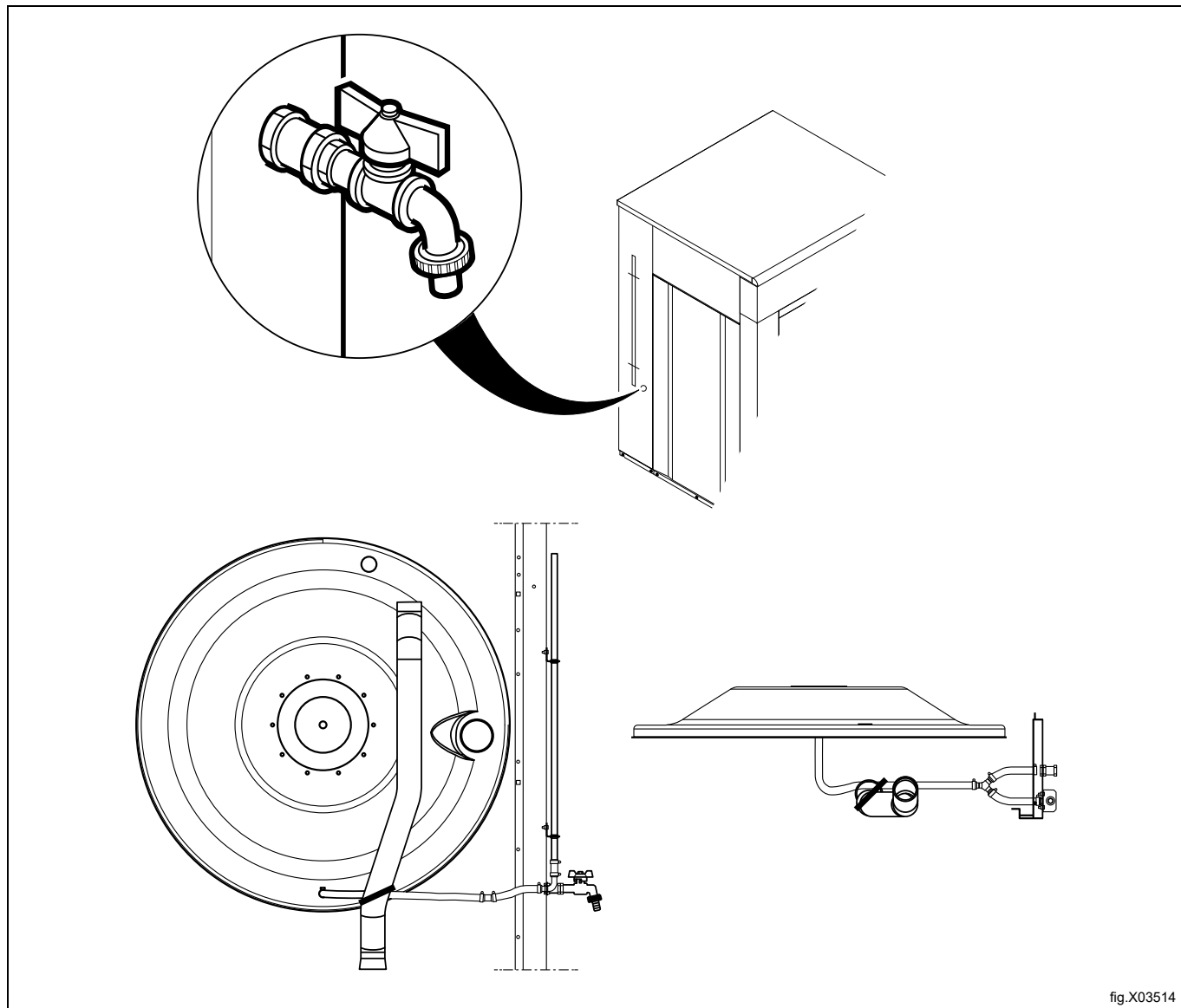

fig.X03514

### 12.1 Setup/Using

Make marks on the level tube to measure for example when a known water volume has been filled-in into the drum. A tip is to mount a scale next to the level tube.

Collect the water samples from the test tap when needed.

---

## 13 At first power up

When the installation is complete and the power is connected for the first time you will be forced to make some settings. Follow the instructions on the display. When one setting is ready you will automatically enter the next one.

If installation is made in a public area, it is only allowed to select the below segments:

APARTMENT AUTO DOSING

APARTMENT MANUAL DOSING

APARTMENT BUILDING MATS

LAUNDROMAT/LAUNDERETTE

LAUNDROMAT/LAUNDERETTE WASCOMAT

LAUNDROMAT/LAUNDERETTE MENCH

CAMPING/MARINA

OTHER SELF SERVICE

## 14 Function check



May only be carried out by qualified personnel.



A function check must be made when the installation is finished and before the machine can be ready to be used.

Open the manual water valves.

Start a program.

- Check that the drum rotates normally and that there are no unusual noises.
- Check that there are no leaks in water supply/drain connections.
- Check that water passes through the detergent container.
- Check that the door cannot be opened during a program.

### Ready to use

If all tests are OK the machine is now ready to be used.

If some of the tests failed, or deficiencies or errors are detected, please contact your local service organisation or dealer.

## 15 Disposal information

### 15.1 Disposal of appliance at end of life

Before disposing of the machine, make sure to carefully check its physical condition, and in particular any parts of the structure that can give or break during scrapping.

The machine's parts must be disposed of in a differentiated way, according to their different characteristics (e.g. metals, oils, greases, plastic, rubber, etc.).

Different regulations are in force in the various countries, therefore comply with the provisions of the laws and competent bodies in the country where scrapping takes place.

In general, the appliance must be taken to a specialised collection/scrapping centre.

Dismantle the appliance, grouping the components according to their chemical characteristics, remembering that the compressor contains lubricant oil and refrigerant fluid which can be recycled, and that the refrigerator and heat pump components are special waste assimilable with urban waste.

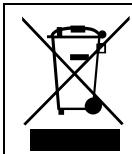

The symbol on the product indicates that this product should not be treated as domestic waste, but must be correctly disposed of in order to prevent any negative consequences for the environment and human health. For further information on the recycling of this product, contact the local dealer or agent, the Customer Care service or the local body responsible for waste disposal.



#### Note!

**When scrapping the machine, any marking, this manual and other documents concerning the appliance must be destroyed.**

### 15.2 Disposal of packing

The packing must be disposed of in compliance with the current regulations in the country where the appliance is used. All the packing materials are environmentally friendly.

They can be safely kept, recycled or burned in an appropriate waste incineration plant. Recyclable plastic parts are marked as following examples.

	Polyethylene: <ul style="list-style-type: none"> <li>• Outer wrapping</li> <li>• Instructions bag</li> </ul>
	Polypropylene: <ul style="list-style-type: none"> <li>• Straps</li> </ul>
	Polystyrene foam: <ul style="list-style-type: none"> <li>• Corner protectors</li> </ul>







Electrolux Professional AB  
341 80 Ljungby, Sweden  
[www.electroluxprofessional.com](http://www.electroluxprofessional.com)