

Maintenance Manual

Tumble dryer

TD6–7
Type N1...



Electrolux
PROFESSIONAL







Contents

Contents



| | | |
|-------|--|----|
| 1 | Symbols | 5 |
| 2 | General | 5 |
| 3 | Maintenance | 7 |
| 3.1 | Every day | 7 |
| 3.2 | Machines with heat pump | 9 |
| 3.2.1 | Second lint filter | 9 |
| 3.2.2 | Special filter | 10 |
| 3.3 | Drain | 11 |
| 3.4 | Condense water pump (option) | 12 |
| 4 | Maintenance to be carried out by qualified service personnel | 12 |
| 4.1 | Clean the glide surface for the RMC graphite collector | 12 |
| 4.2 | Clean the motor and the area over the drum | 13 |
| 4.3 | Clean the fan motor unit | 15 |
| 4.4 | Maintenance of the heat pump unit | 18 |
| 4.4.1 | Clean the inside of the heat pump unit | 18 |

The manufacturer reserves the right to make changes to design and component specifications.

1 Symbols

| | |
|--|--|
|  | Caution |
|  | Caution, hot surface |
|  | Caution, high voltage |
|  | Warning, risk of fire / flammable material |
|  | Danger, crush hazard |
|  | Read the instructions before using the machine |

2 General

| | | |
|---|--|---|
|  | Maintenance of the heat pump unit must only be made by trained and educated personnel! |  |
|---|--|---|

It is the responsibility of the owner of the machine/the laundry manager to make sure that the following maintenance is performed.

- Check and clean the filter on a regular basis.
- There are two warning messages indicating that the second filter shall be cleaned:
 1. "CLEAN FIRST AND SECOND FILTER."
 2. "CLEAN FIRST AND SECOND FILTER. IF NOTICE REMAINS, CONTACT RESPONSIBLE FOR CHANGING THE SPECIAL FILTER."

If the first and second filter has been cleaned but the warning message remain on the next drying cycle, the special filter must be cleaned or replaced.

- There are two messages indicating that the special filter has to be cleaned or replaced:
 1. "CLEAN FIRST AND SECOND FILTER. IF NOTICE REMAINS, CONTACT RESPONSIBLE FOR CHANGING THE SPECIAL FILTER."

If the first and second filter has been cleaned but the warning message remain on the next drying cycle, the special filter must be cleaned or replaced.

2. "AIRFLOW OBSTRUCTED. CONTACT RESPONSIBLE."

The special filter can be cleaned only once with a vacuum cleaner, provided it does not show any structural damage that may let some lint pass through. After the special filter has been cleaned once, the next time the alarm is displayed, it shall be replaced.

- Due to various installations and depending on the use of the machine other intervals may be necessary.

Note!

Adding too much detergent in the washing process will increase cleaning interval of the lint filters.

Note!

Hard water may require more maintenance of filters due to tendency of using too much detergent in the washing process.

Note!

Lack of maintenance may deteriorate the performance of the machine and may cause damage to components.

Note!

All three lint filters must be in place when the machine is running.

3 Maintenance

3.1 Every day

Check that the machine does not operate with the door or the filter drawer open, if so, the machine must be placed out of order until repairs are made.

Note!

Contact qualified service personnel to disconnect power from the affected machine.

Clean the door, door glass, door gasket and other external parts.

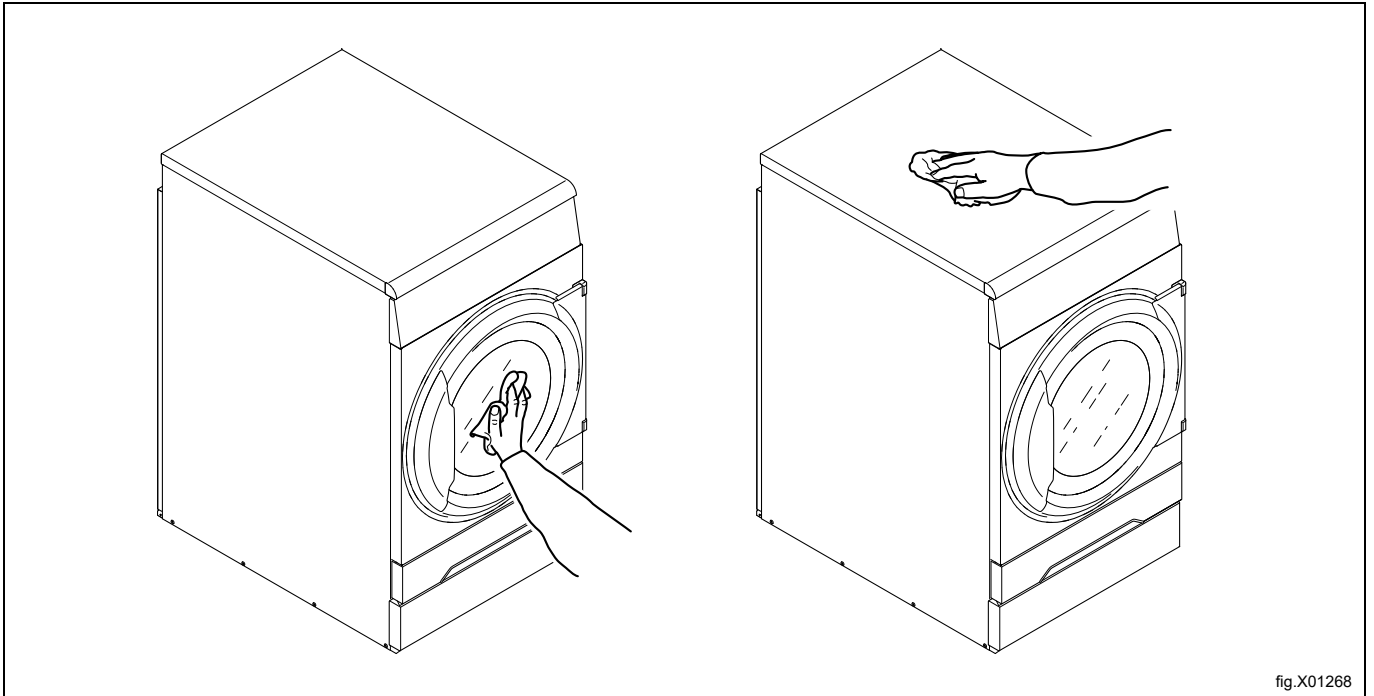

Check the filter and filter drawer. Clean if necessary.

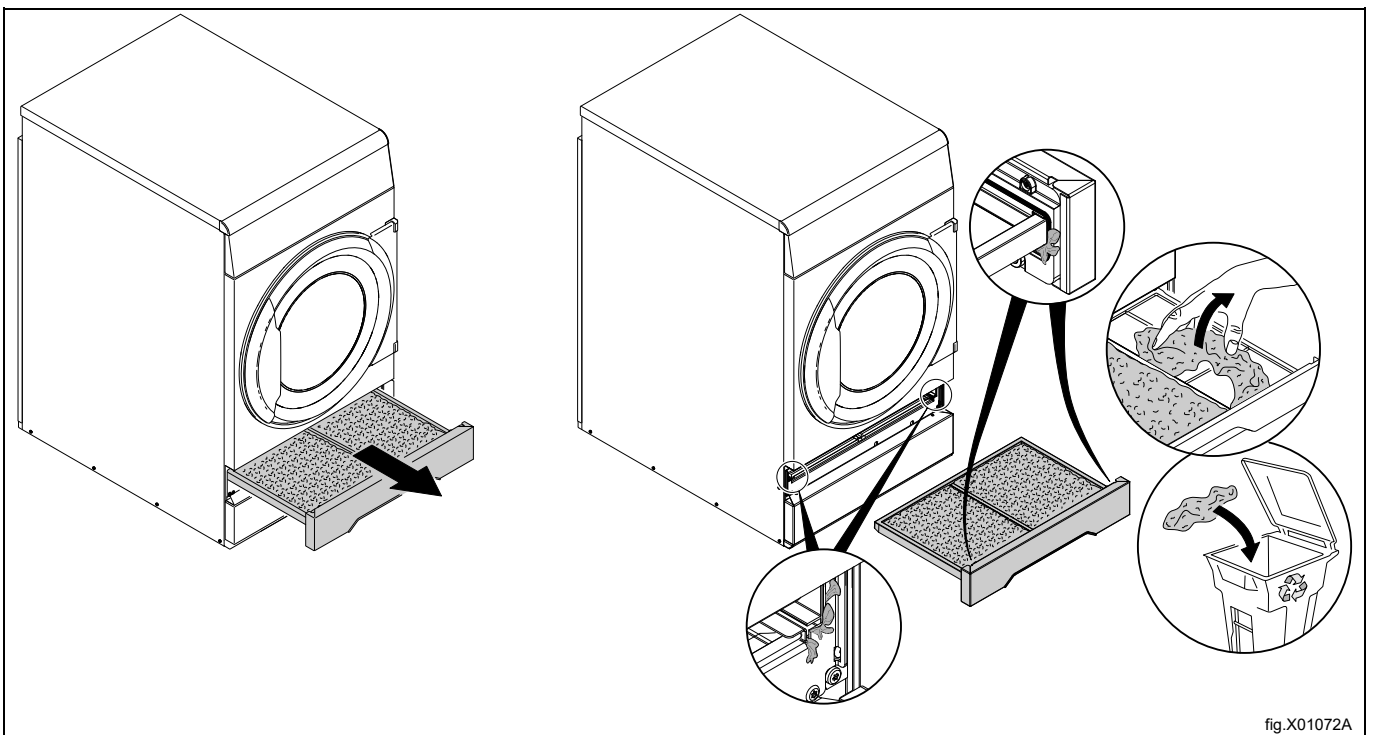



Remove any lint and dust around the machine.



3.2 Machines with heat pump

3.2.1 Second lint filter

There are two warning messages indicating that the second filter shall be cleaned:

1. "CLEAN FIRST AND SECOND FILTER."
2. "CLEAN FIRST AND SECOND FILTER. IF NOTICE REMAINS, CONTACT RESPONSIBLE FOR CHANGING THE SPECIAL FILTER."

If the first and second filter has been cleaned but the warning message remain on the next drying cycle, the special filter must be cleaned or replaced.

Remove the filter drawer and pull out the second lint filter.

Clean the second lint filter.

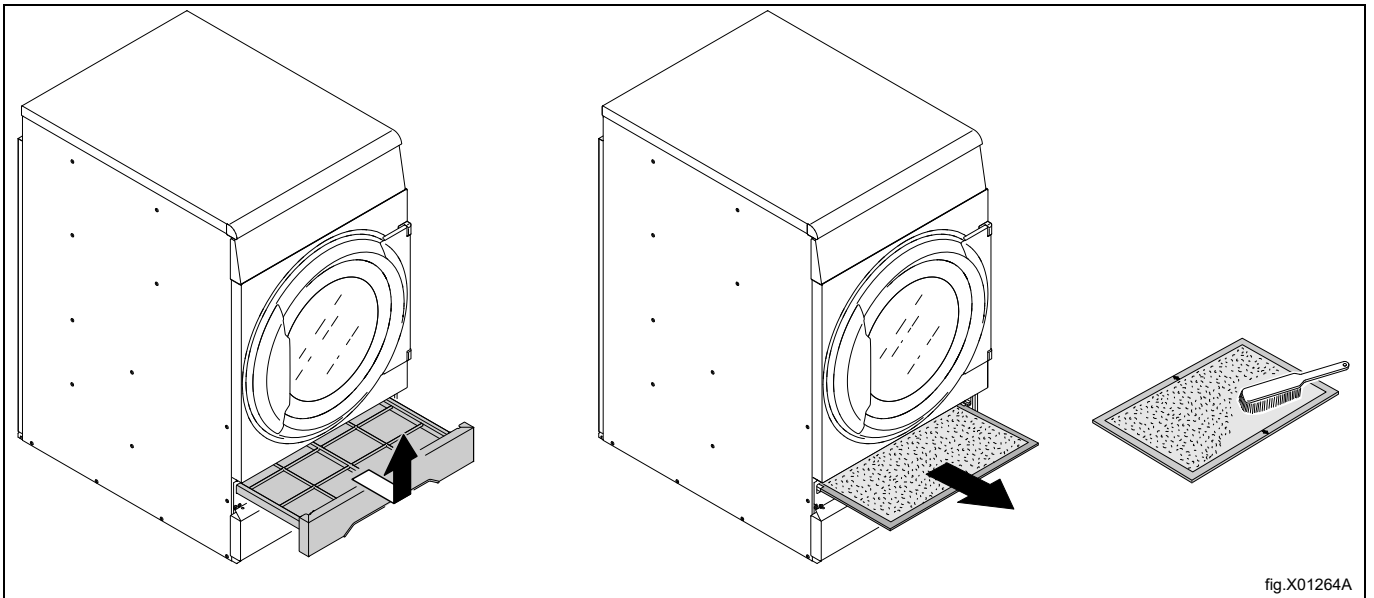

When the second lint filter has been cleaned, insert the second lint filter and the filter drawer.

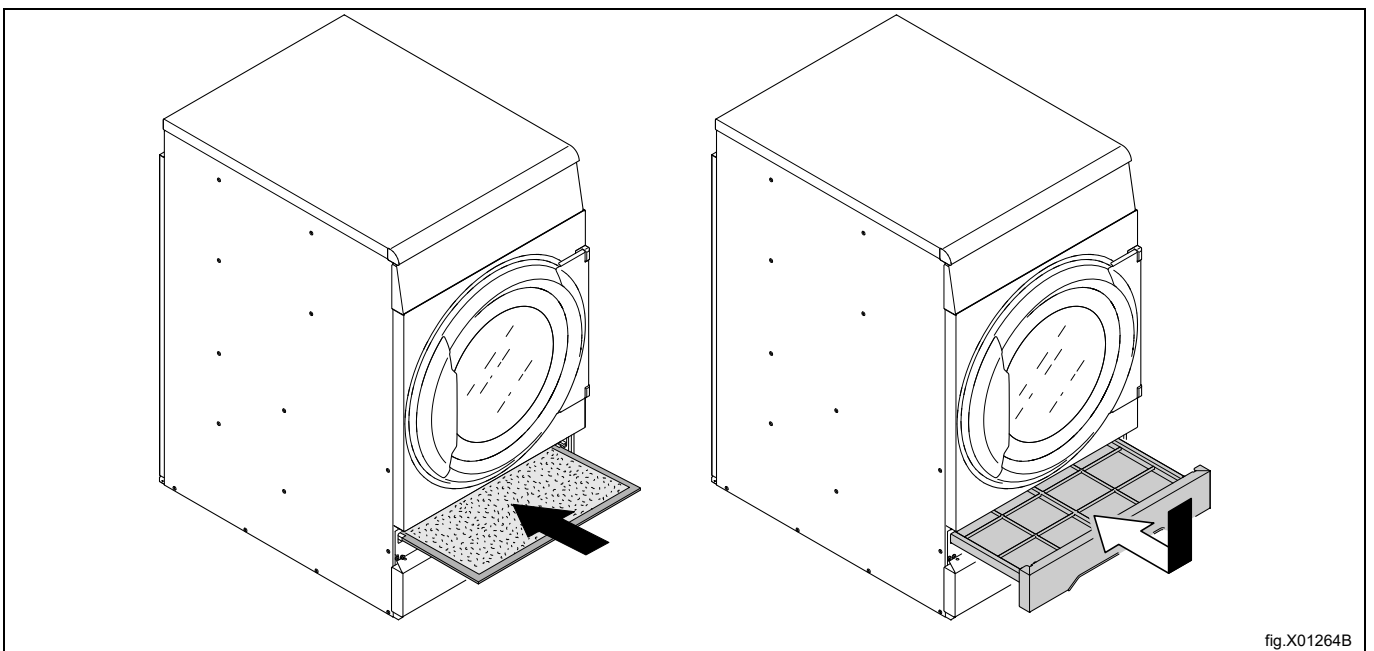

3.2.2 Special filter

Note!

There are two messages indicating that the special filter has to be cleaned or replaced:

- “CLEAN FIRST AND SECOND FILTER. IF NOTICE REMAINS , CONTACT RESPONSIBLE FOR CHANGING THE SPECIAL FILTER .”

If the first and second filter has been cleaned but the warning message remain on the next drying cycle, the special filter must be cleaned or replaced.

- “AIRFLOW OBSTRUCTED . CONTACT RESPONSIBLE .”

The special filter can be cleaned only once with a vacuum cleaner, provided it does not show any structural damage that may let some lint pass through. After the special filter has been cleaned once, the next time the relevant alarm is displayed, it shall be replaced.

Note!

Do not use water to clean the special filter.

Disconnect the power to the machine.

Remove the filter drawer.

Loosen the two lower screws a little bit and loosen the three upper screws completely and demount the bracket.

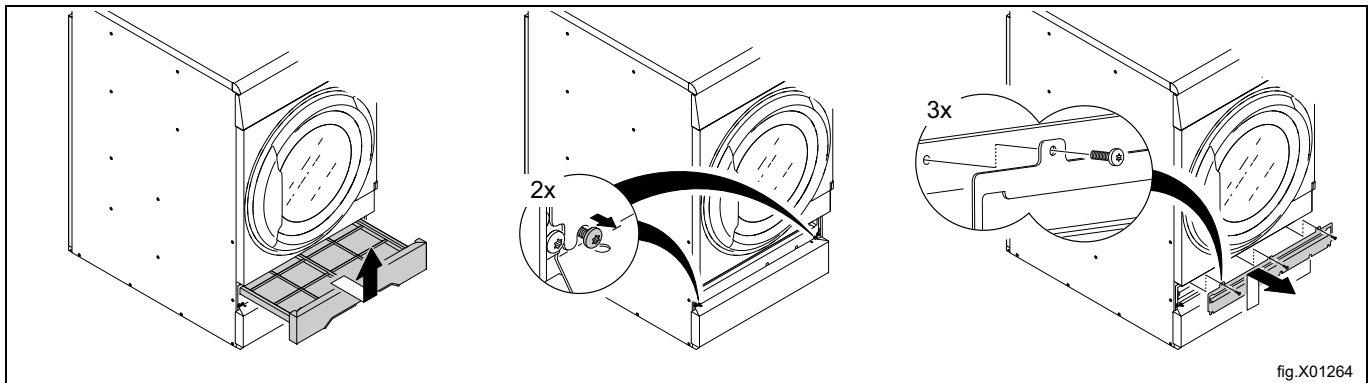

fig.X01264

Remove the special filter.

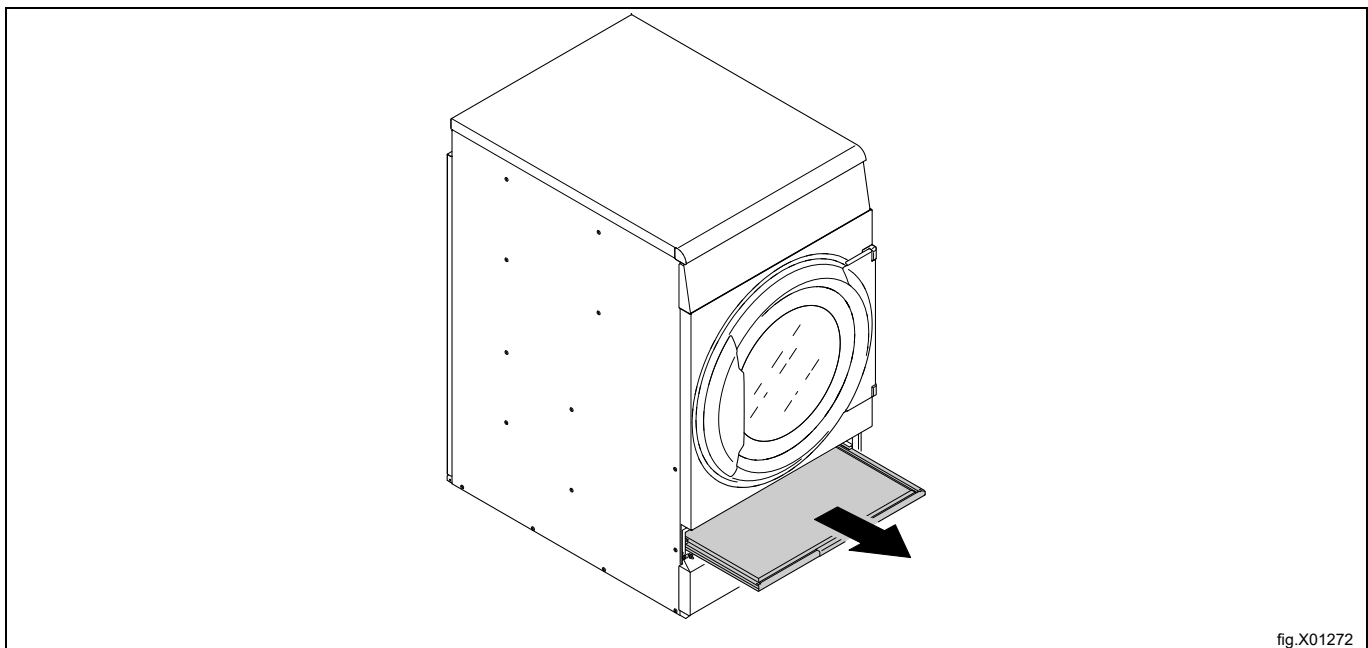
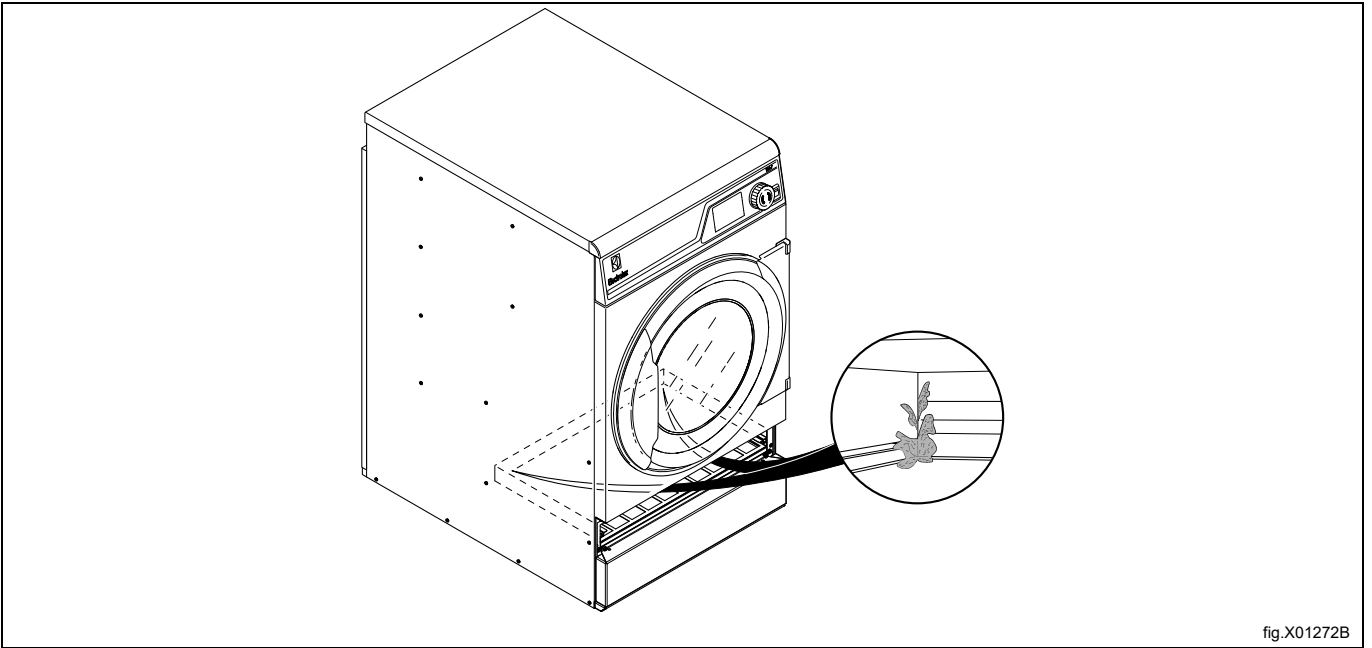

fig.X01272

Clean the inside of the filter housing and around the internal corners.



Insert the new special filter and remount the bracket and insert the filter drawer.

- The special filter can be ordered as spare part in set of 5 or 10 pcs. Please refer to the “Spare parts catalogue” for correct art. No.

3.3 Drain

At regular basis, check and clean the drain.

Clean the inside of the pipe (A).

If there is a hose connected to the pipe (A), also remove and clean the hose.

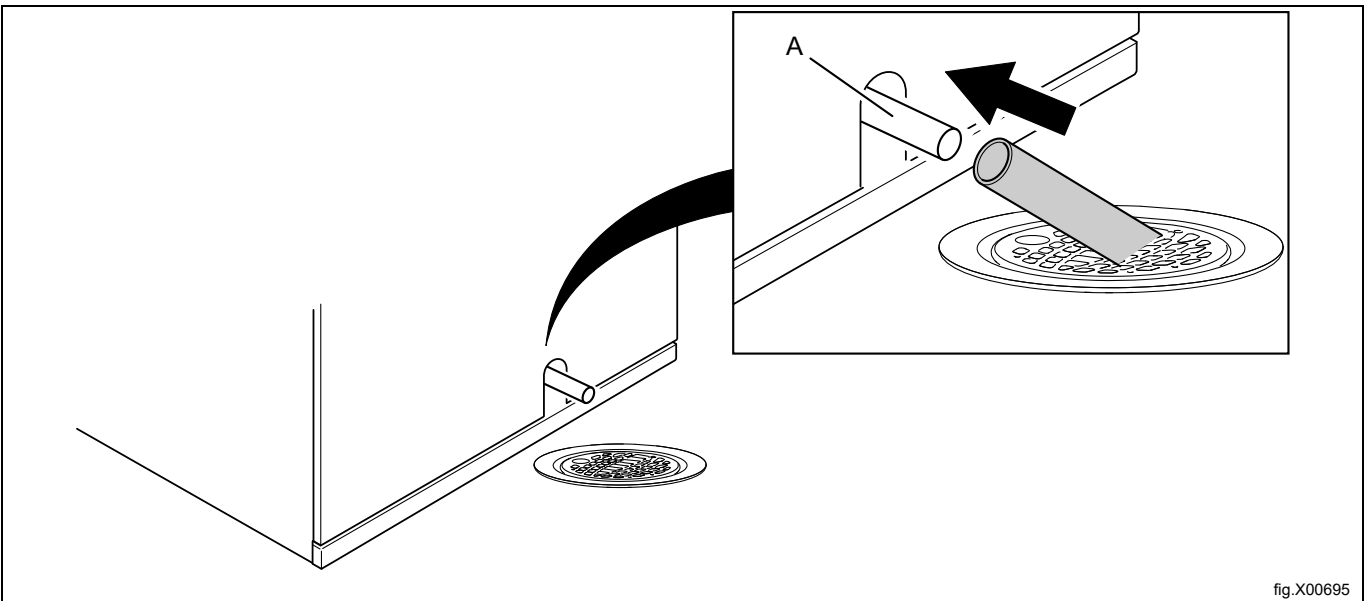

3.4 Condense water pump (option)

It is recommended to clean or replace the filter in the condense water pump every month or after 100 hours of operation. If not, this will decrease the lifetime of the condense water pump and there will be water leakages on the floor because the condensed water inside the machine is blocked by the clogged filter.

The purpose of the filter is to prevent foreign debris from entering the condense water pump.

- Disconnect the power to the machine.
- Remove the filter according to the figure (1–2).
- Clean or replace the filter. Make sure to insert the filter in correct position (3).

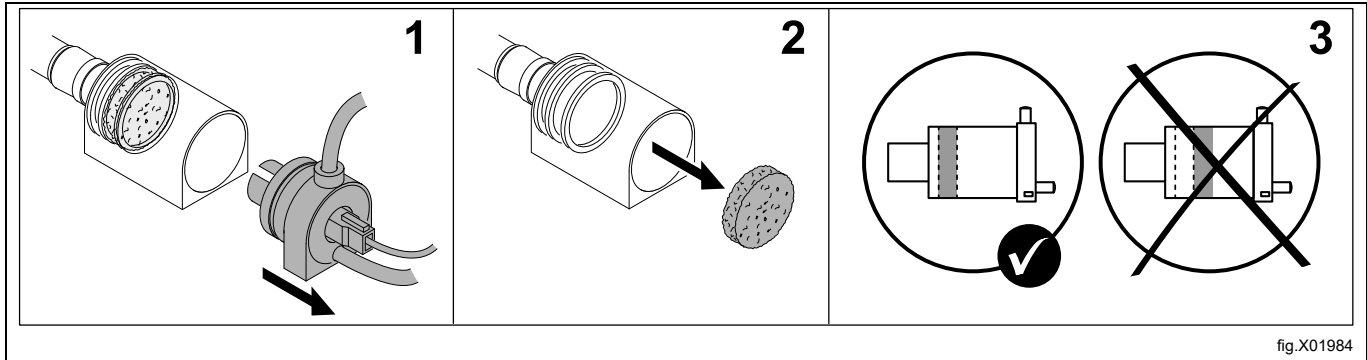

fig.X01984

4 Maintenance to be carried out by qualified service personnel

After 1600 hours of operation or once a year, whichever comes first, contact qualified service personnel to perform the following maintenance. If neglected performance will decrease and the machine can be damaged.

For original spareparts please contact your local authorized dealer.

4.1 Clean the glide surface for the RMC graphite collector

At regular basis, wipe off/clean drum and lifters with citric acid (*Acidum citricum*). If soap/softener residue remains, it is recommended also to use a coarse sponge.

Lack of cleaning can reduce the automatic residual moisture control which will make the load being moister than requested when the program has ended.

- Disconnect the power to the machine.
- Demount the top panel.

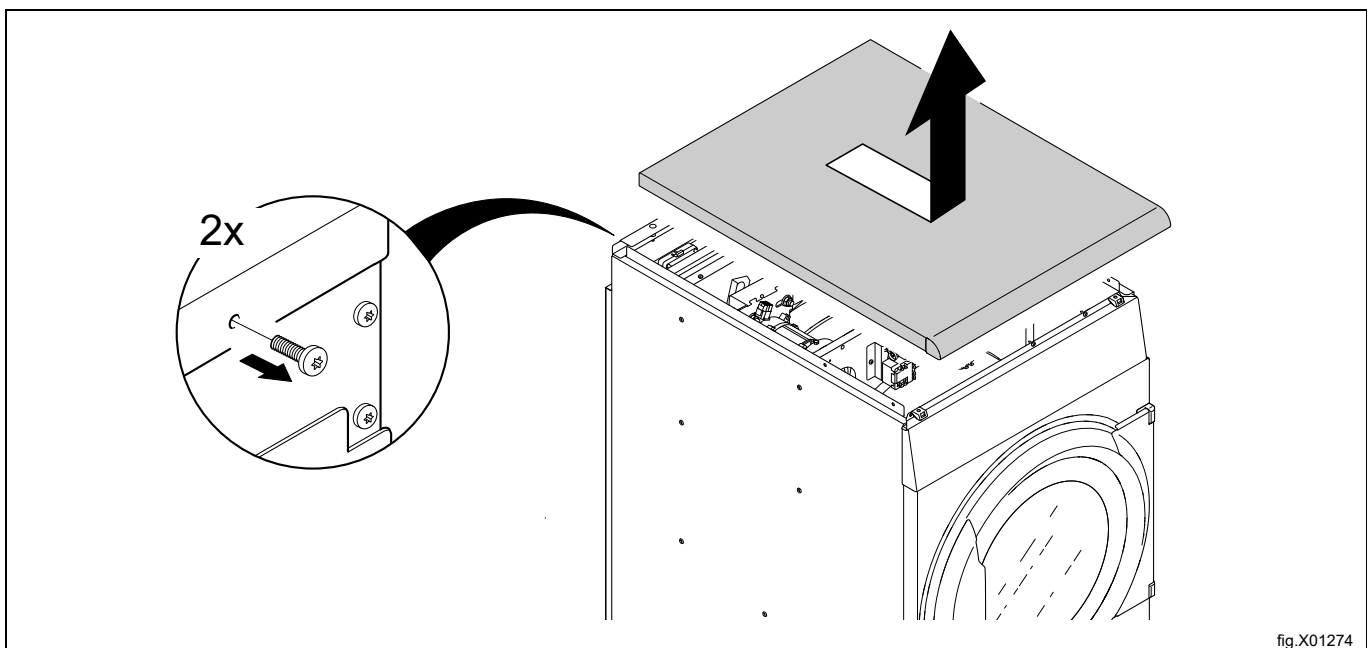
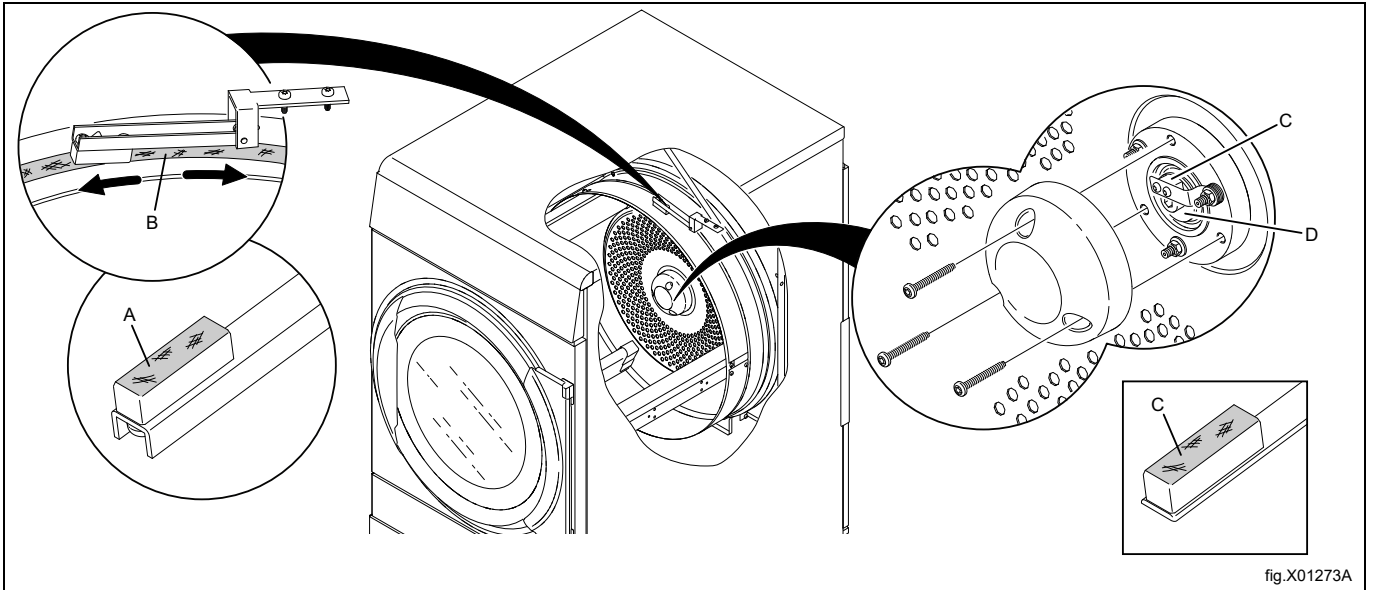

fig.X01274

Clean the glide surface for the RMC graphite collector (A) and on the outside of the drum (B) all the way around the drum.

Clean the graphite collector (C) and washer (D) under the cover bearing.

Use sand paper No. 100–400 to clean.



4.2 Clean the motor and the area over the drum

Disconnect the power to the machine.

Demount the top panel.

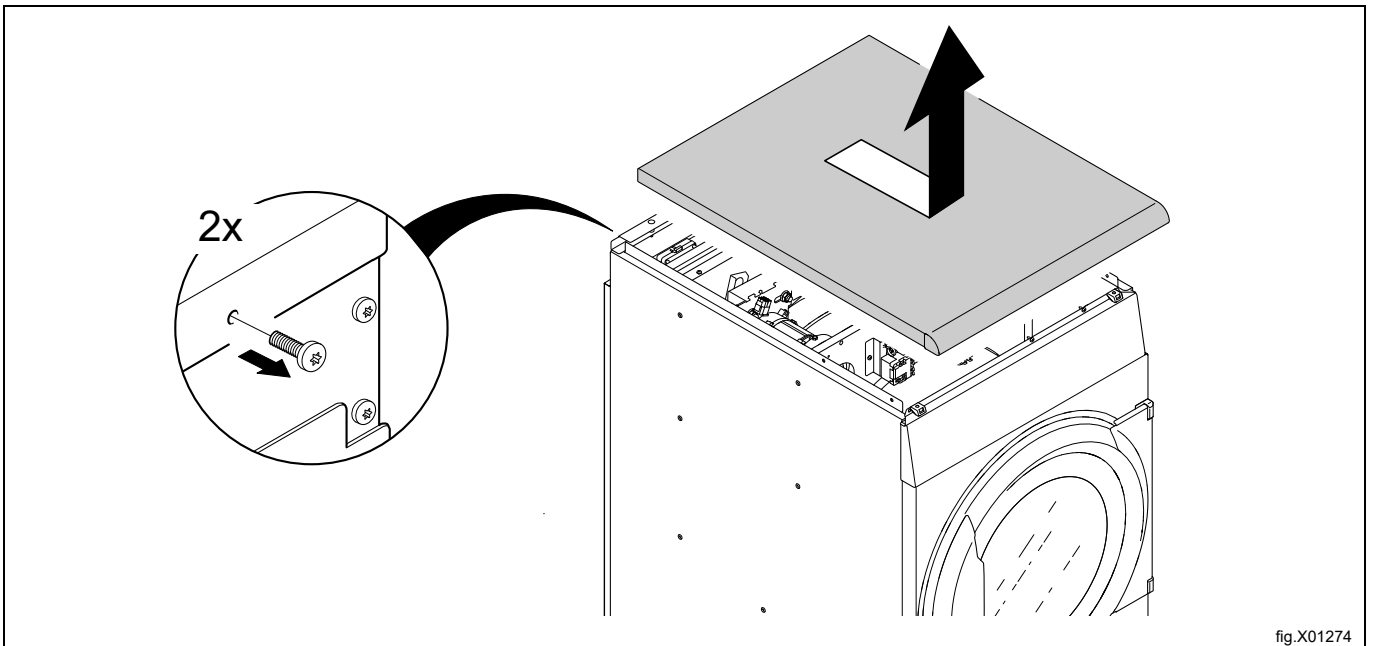

Clean the motor with a vacuum cleaner. Be careful not to damage any parts.

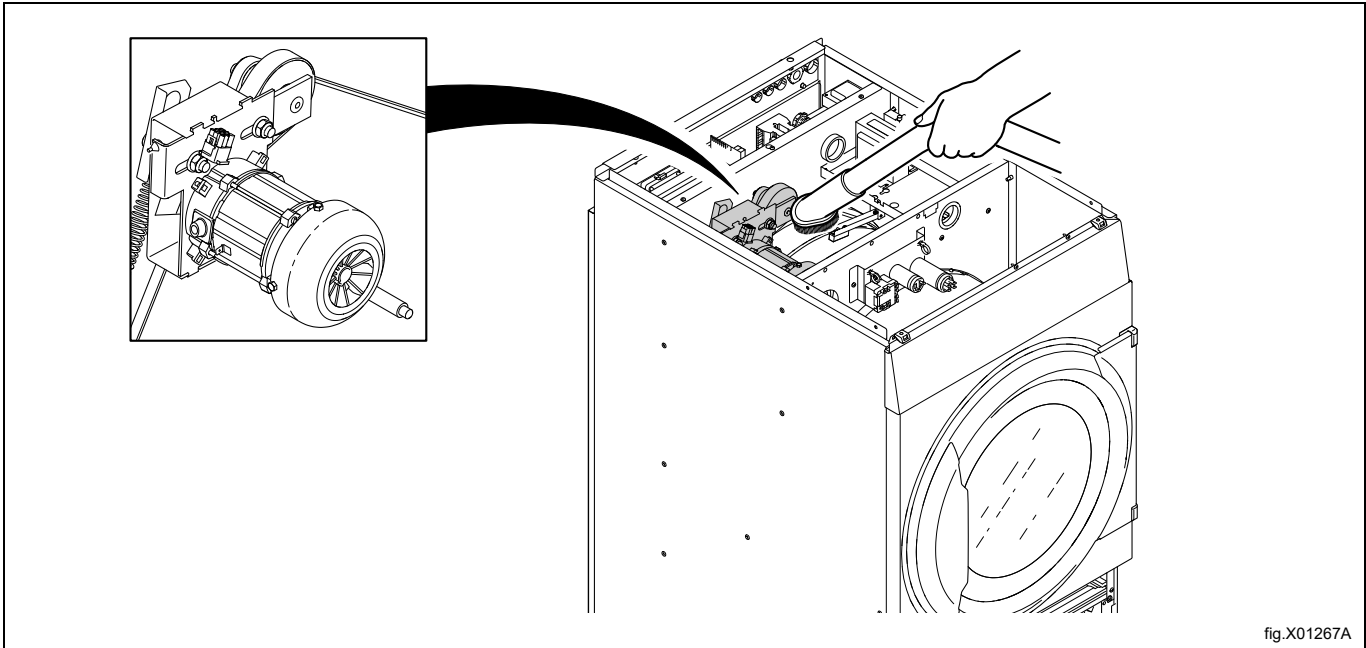

Clean the area over the drum with a vacuum cleaner. Be careful not to damage any parts.
Make sure that all lint has been removed and that all areas are clean before remounting.

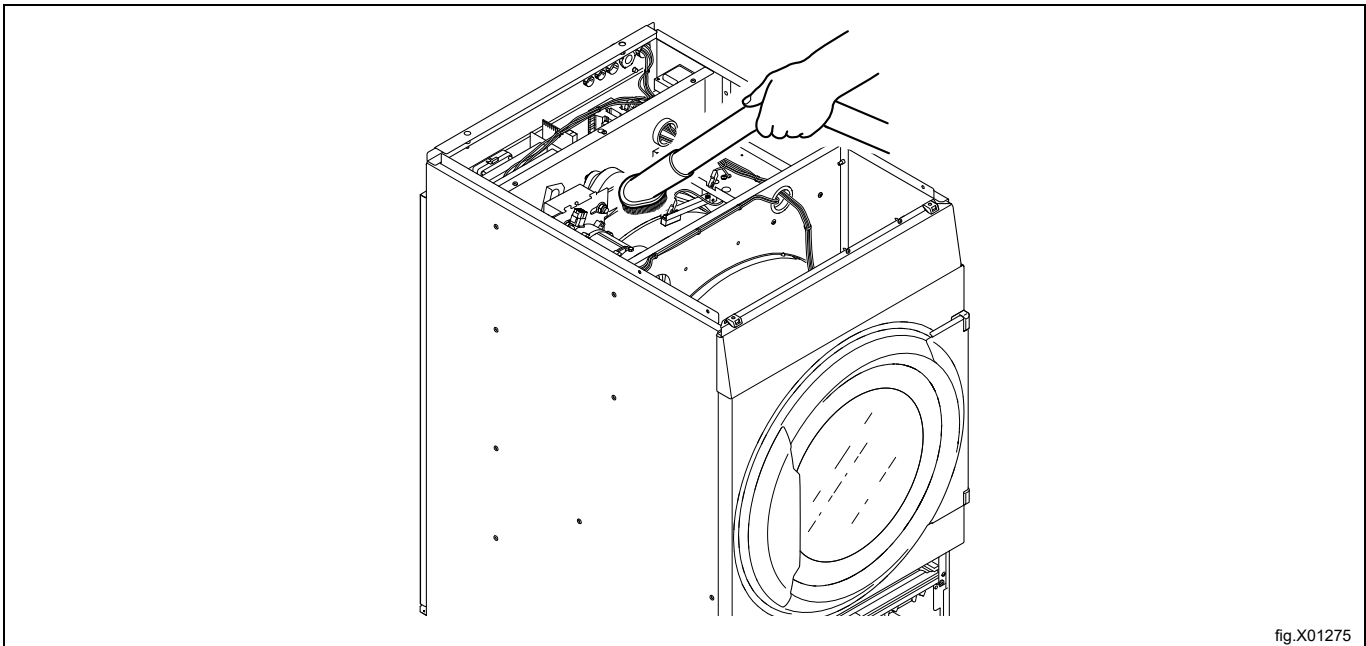

4.3 Clean the fan motor unit

Disconnect the power to the machine.

Remove the filter drawer.

Loosen the five screws and demount the bracket.

Remove the lower front panel.

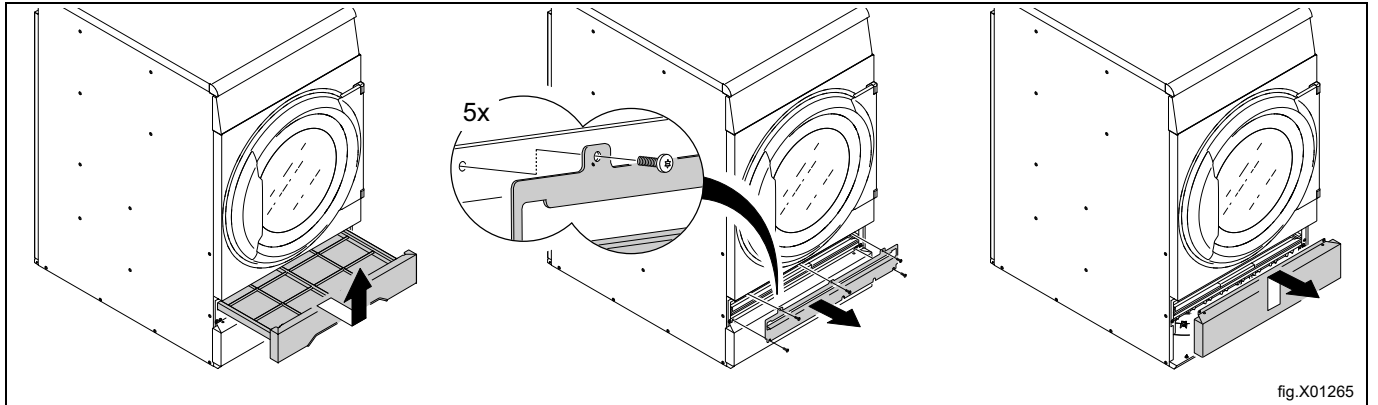

Loosen the rubber hose to the vacuum switch.

Disconnect the cables to the fan motor.

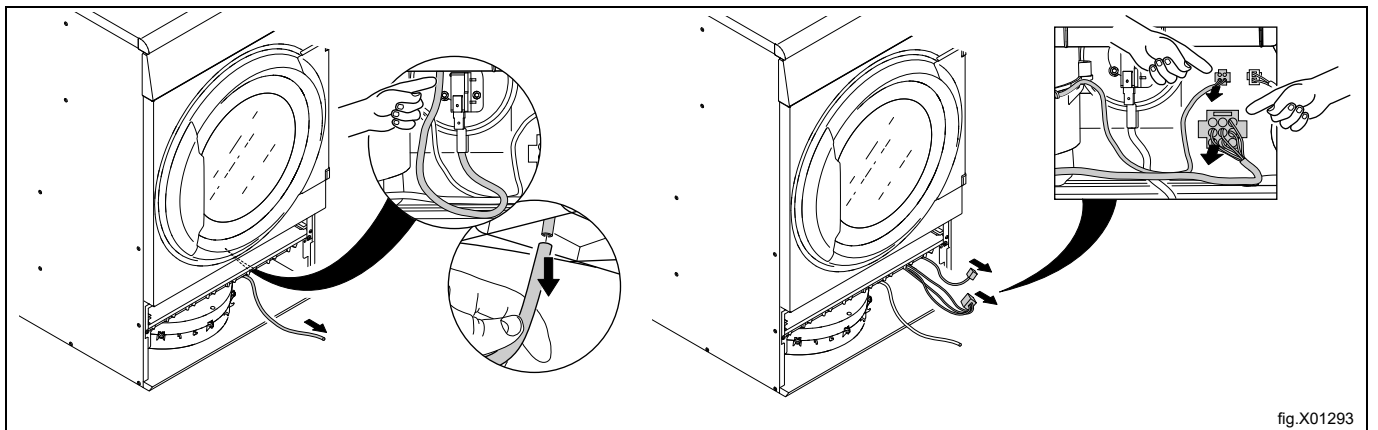

Carefully remove the fan motor unit from the machine.

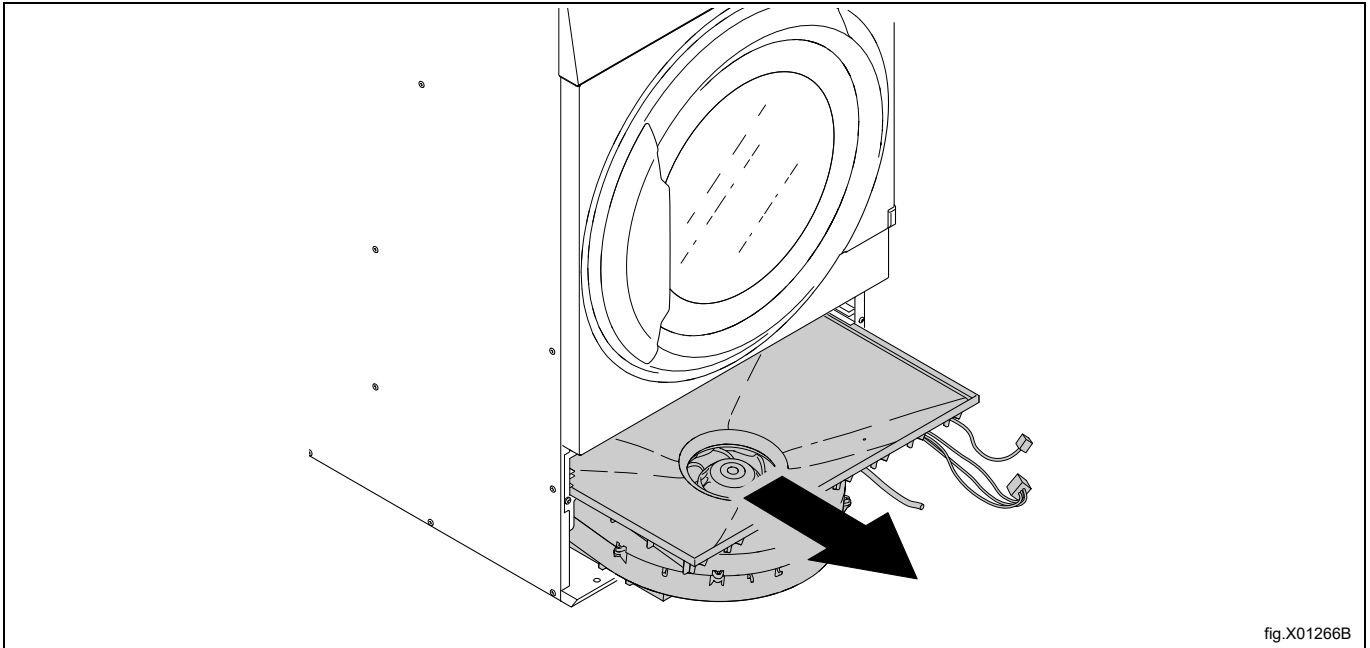

Clean the fan motor unit with a vacuum cleaner. Make sure all parts and sides are clean.

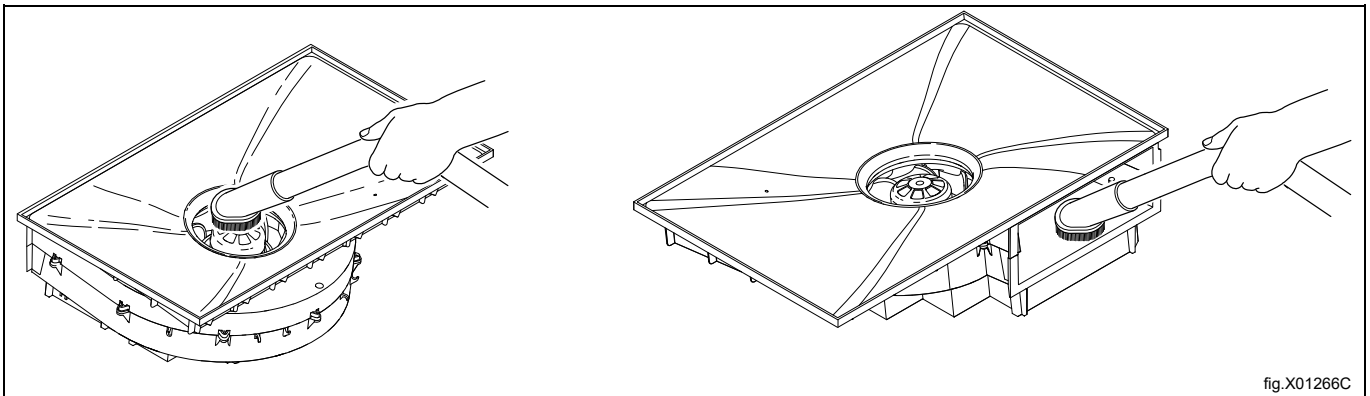

When the fan motor unit has been removed from the machine, clean the fan motor unit area in the machine with a vacuum cleaner.

Make sure that all lint has been removed and that all areas are clean before remounting.

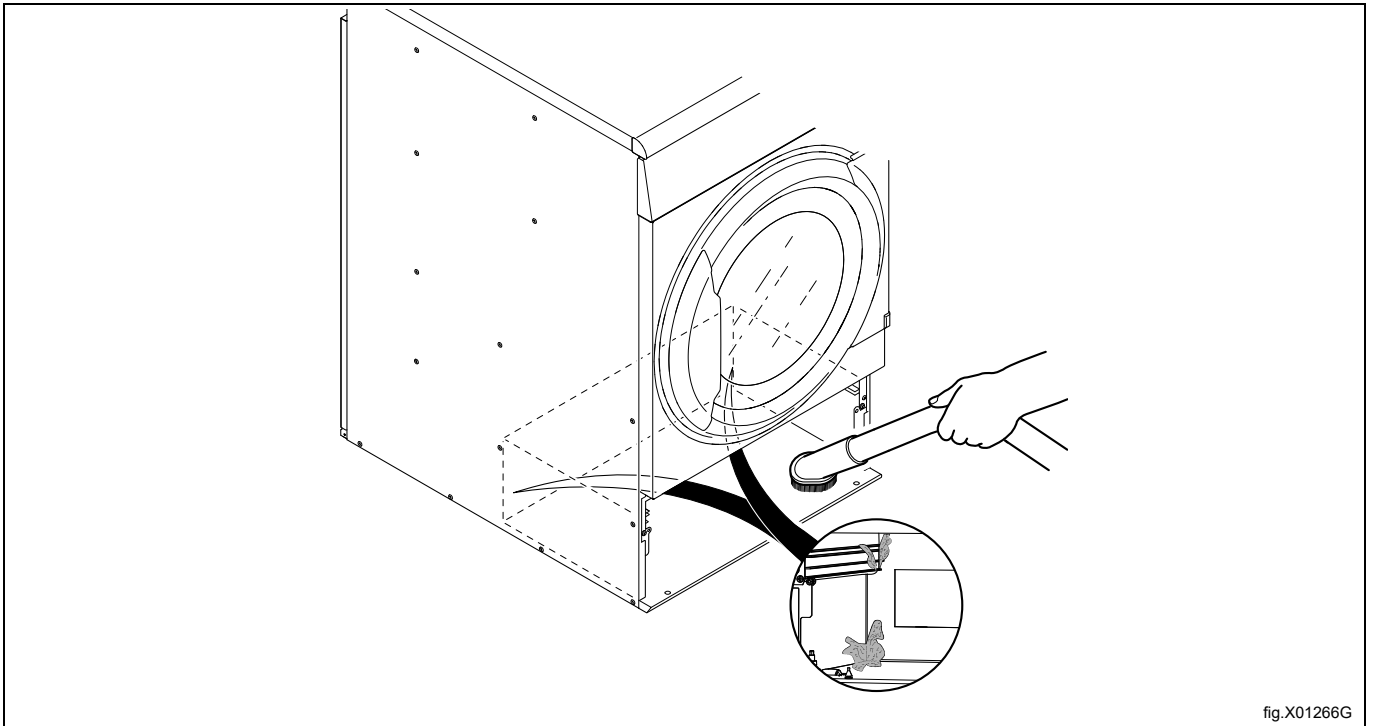

fig.X01266G

4.4 Maintenance of the heat pump unit

4.4.1 Clean the inside of the heat pump unit

Demounting

Disconnect the power to the machine.

Disconnect the hose to the drain (if a hose is connected).

Demount the rear panel.

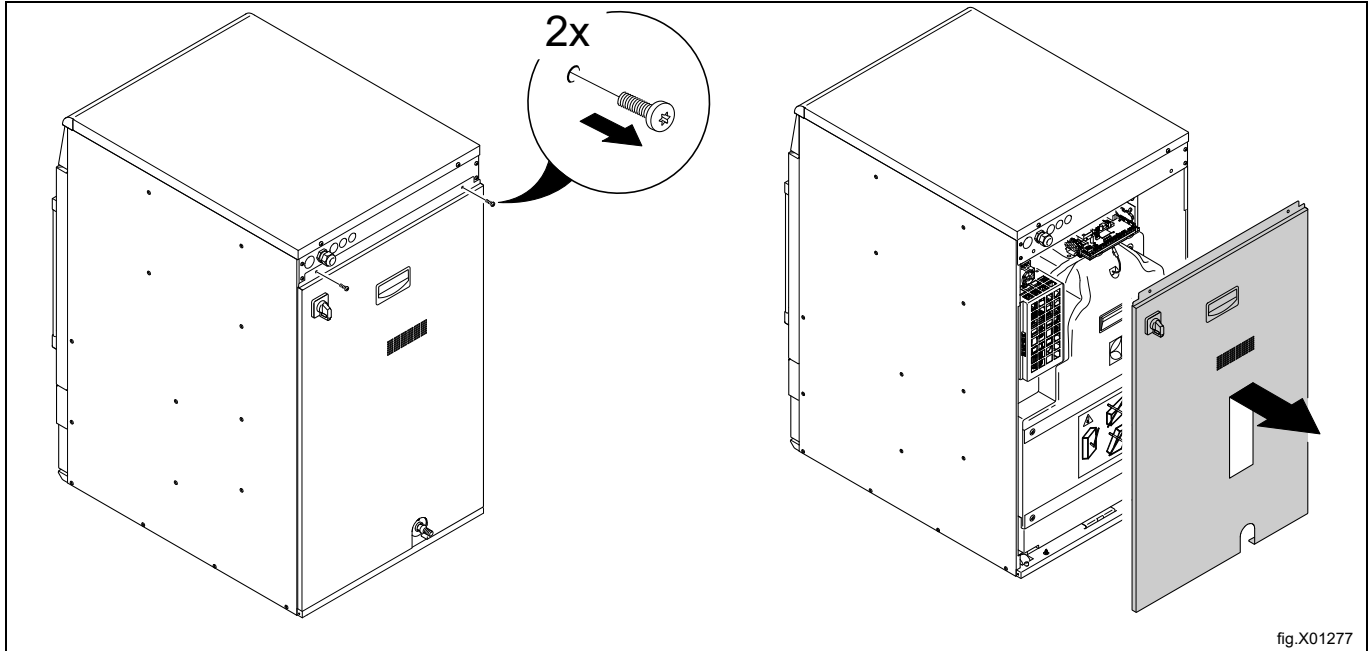

Disconnect the cables from the heat pump unit and secure them on the heat pump unit.

Remove the four screws from the top of the heat pump unit.

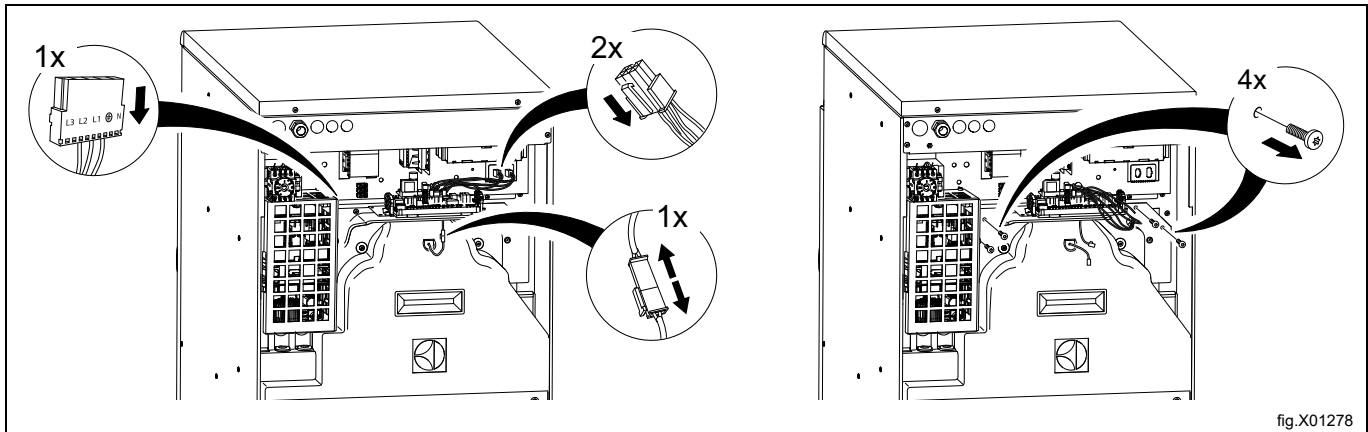

The position of the heat pump unit is secured in the machine by a bracket in the bottom of the heat pump unit. Loosen the two screws (just a little bit to release the bracket). Use a screw driver to lift the bracket over the rail and fasten the screws again to fit the bracket in upper position.

Remove the heat pump unit from the machine by first lifting it up a bit and then pulling it out towards you.

Note!

Do not use the opening (A) to lift the heat pump unit.

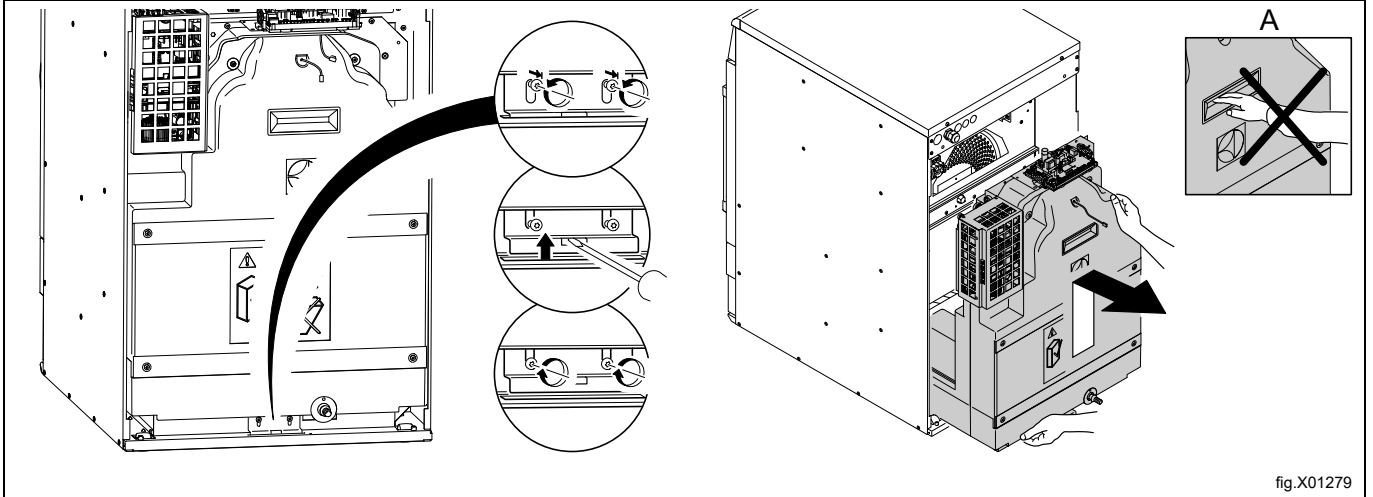

fig.X01279

The heat pump unit can easily be moved by rolling it on the wheels.

Demount the cover to the electric unit.

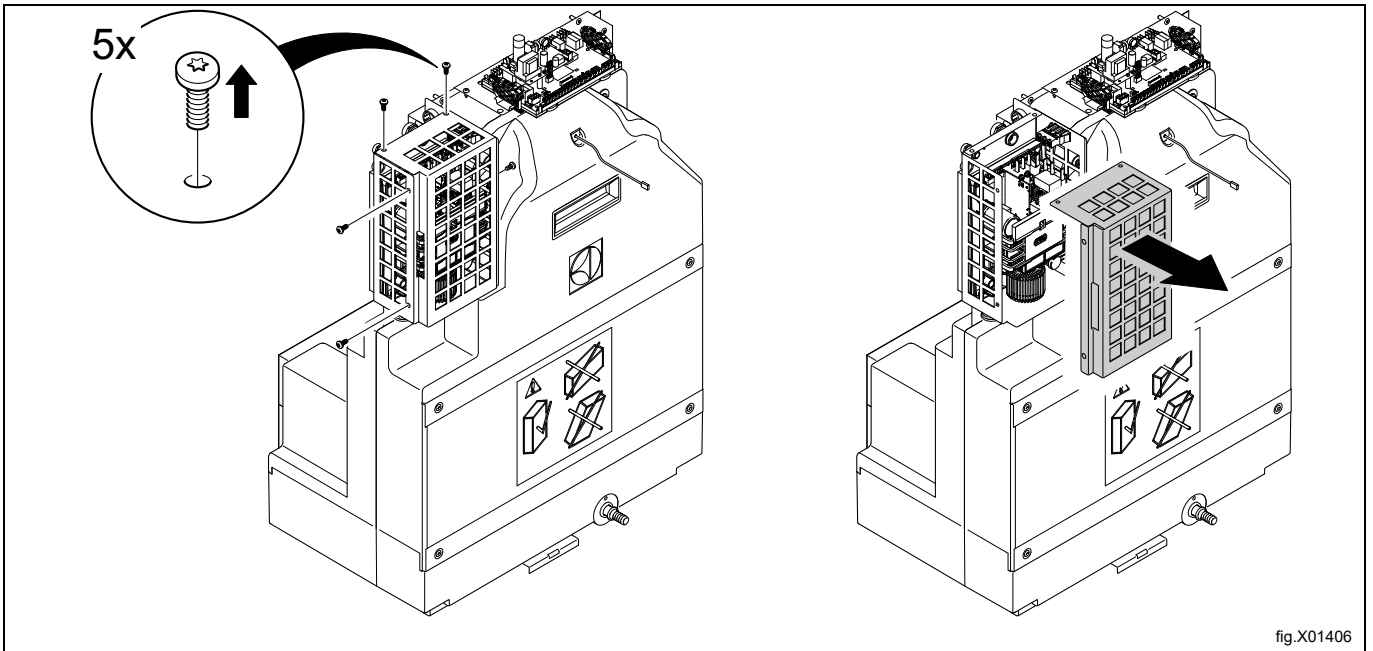

fig.X01406

Remove the two screws and washers on the cover to the heat pump unit.

Demount the two brackets.

Remove the cover to the heat pump unit.

Note!

Do not use the opening (A) when removing the cover to the heat pump unit.

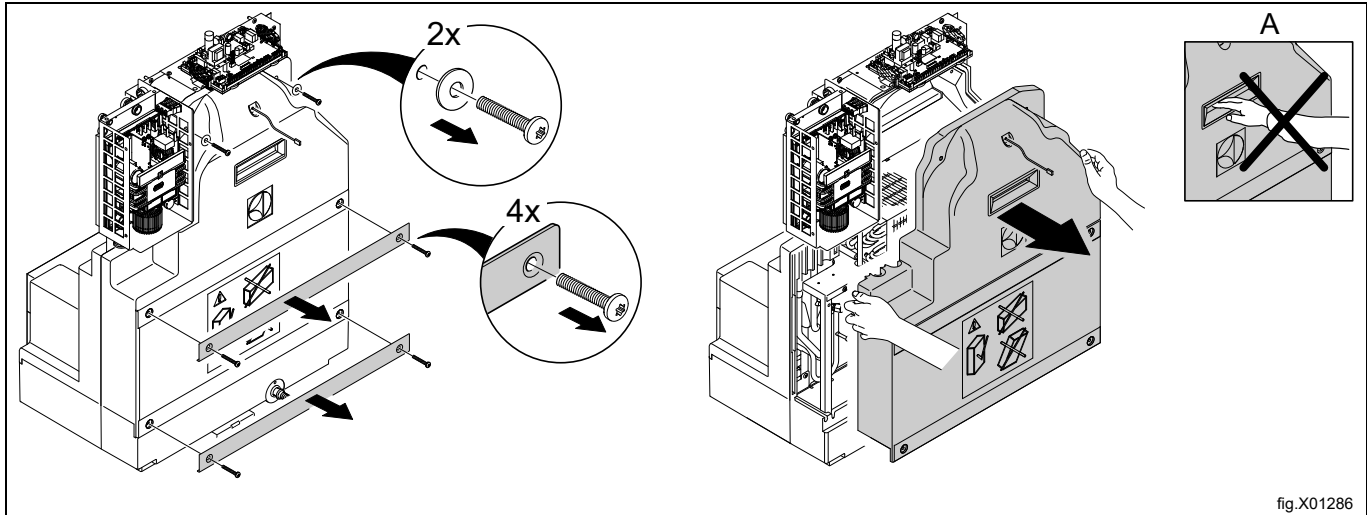

fig.X01286

Cleaning

Clean the condenser and the inside of the heat pump unit with a vacuum cleaner.

If the machine have a diffuser panel (X); remove the diffuser panel.

Clean the diffuser panel and the evaporator with a vacuum cleaner.

Be careful not to damage any parts.

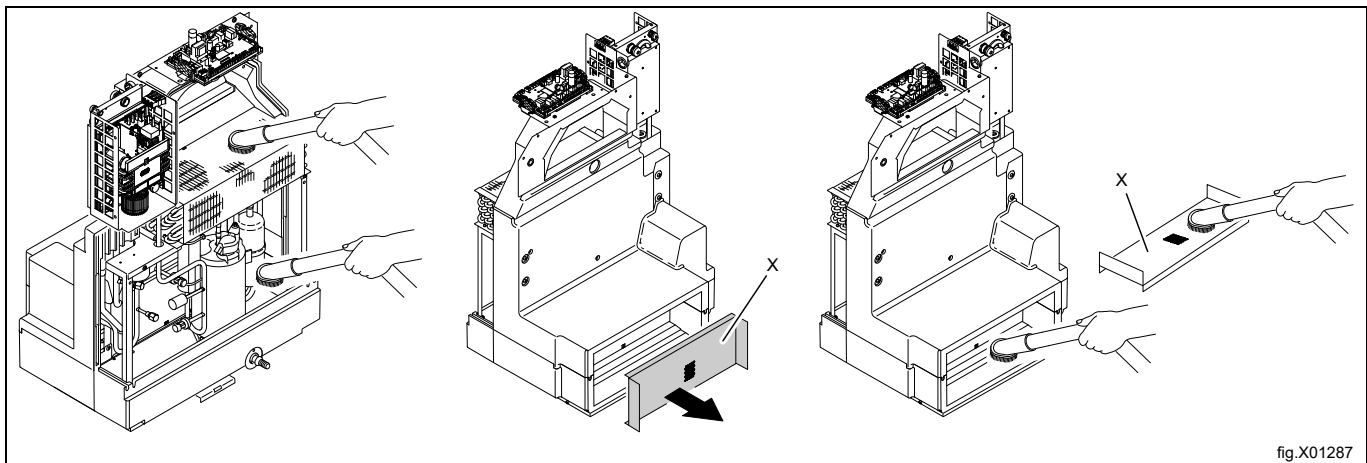

fig.X01287

Cover all electrical components and the electrical connection on top of the compressor (if there is no cover on the compressor) in the heat pump unit to protect them from water splash.

Position the heat pump unit with the drain for condensed water over a floor drain or similar.

Clean the condenser and the inside of the heat pump unit by pouring water on top of the units.

Note!

Do not use high pressure!

Wipe off any remaining water with a cloth.

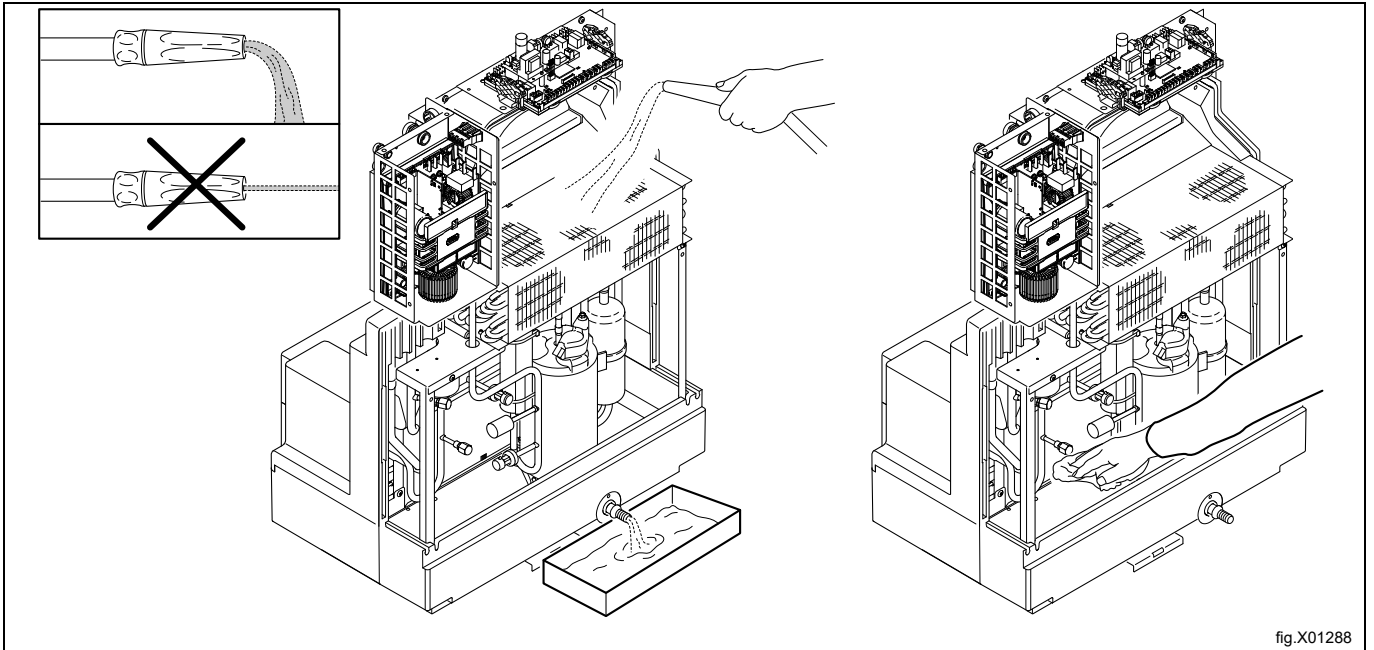

fig.X01288

Clean the evaporator with water.

Note!

Do not use high pressure!

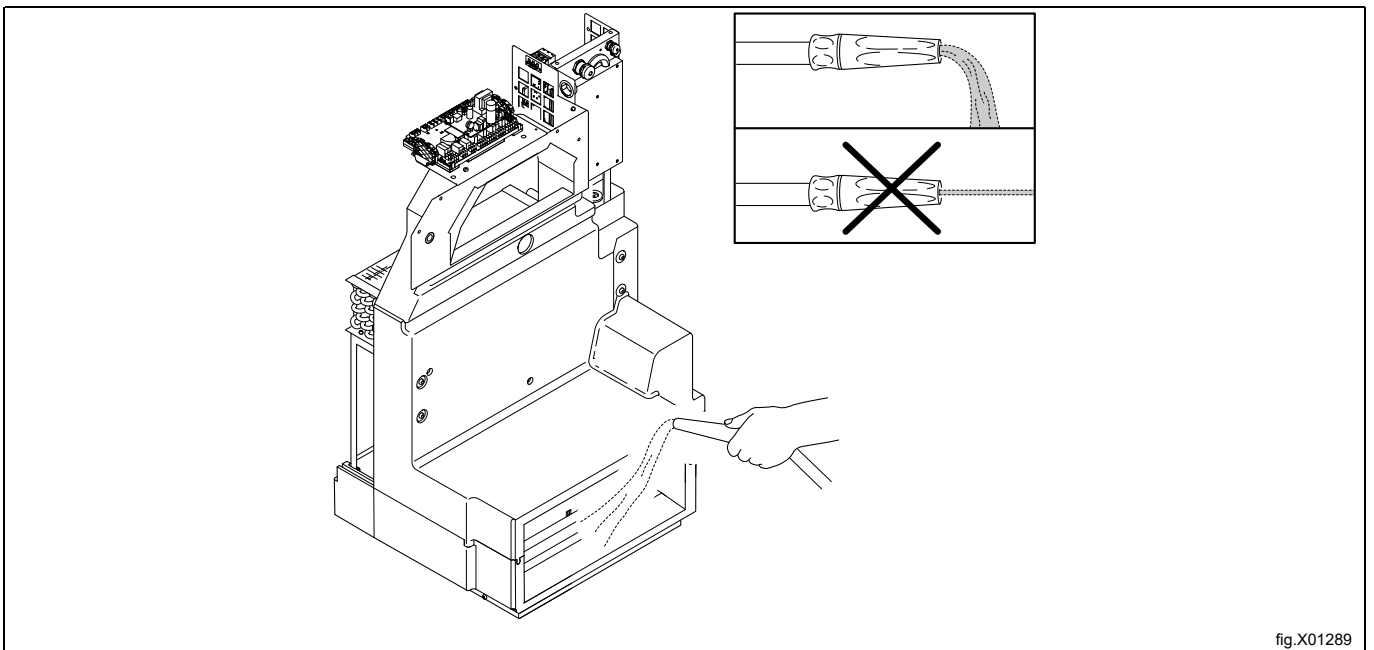

fig.X01289

Make sure that all parts are completely clean and that all dust, lint and water are gone before remounting the heat pump unit.

Remounting

Refit the diffuser panel (X) if it was removed.

Refit the cover to the heat pump unit and make sure it is in position.

Remount the two brackets.

Fasten the cover to the heat pump unit with the two washers and screws.

Note!

Do not use the opening (A) when refitting the cover to the heat pump unit.

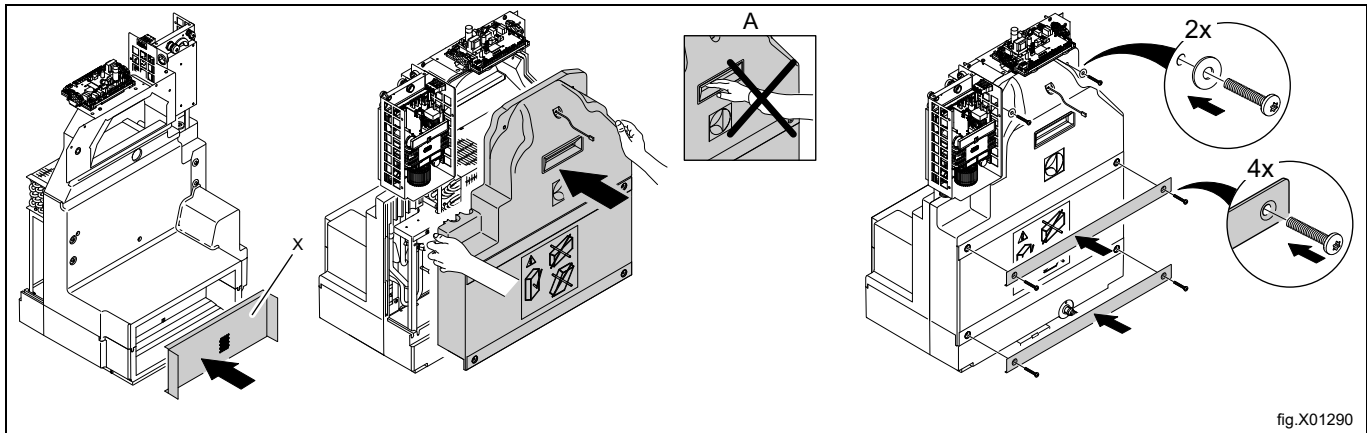

Remount the cover to the electric unit.

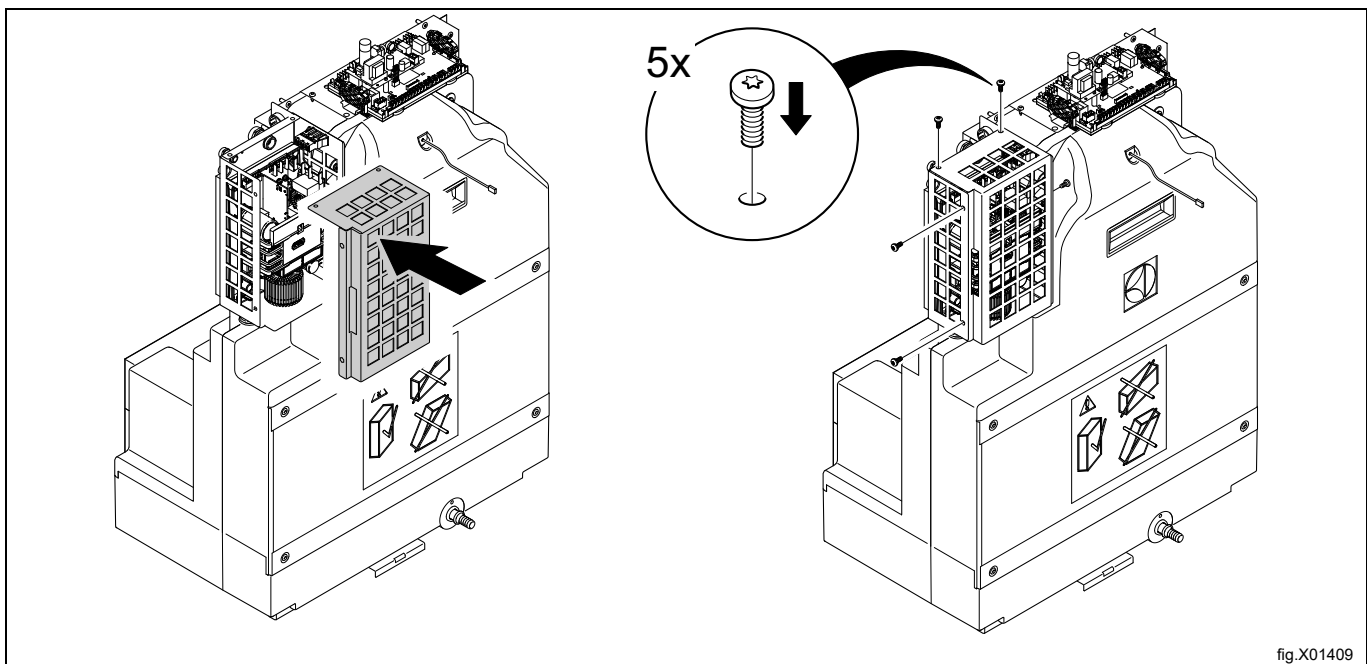

Position the heat pump unit into the machine.

Loosen the two screws a little bit to release the bracket (make sure the bracket is in position behind the rail) and fasten the screws again.

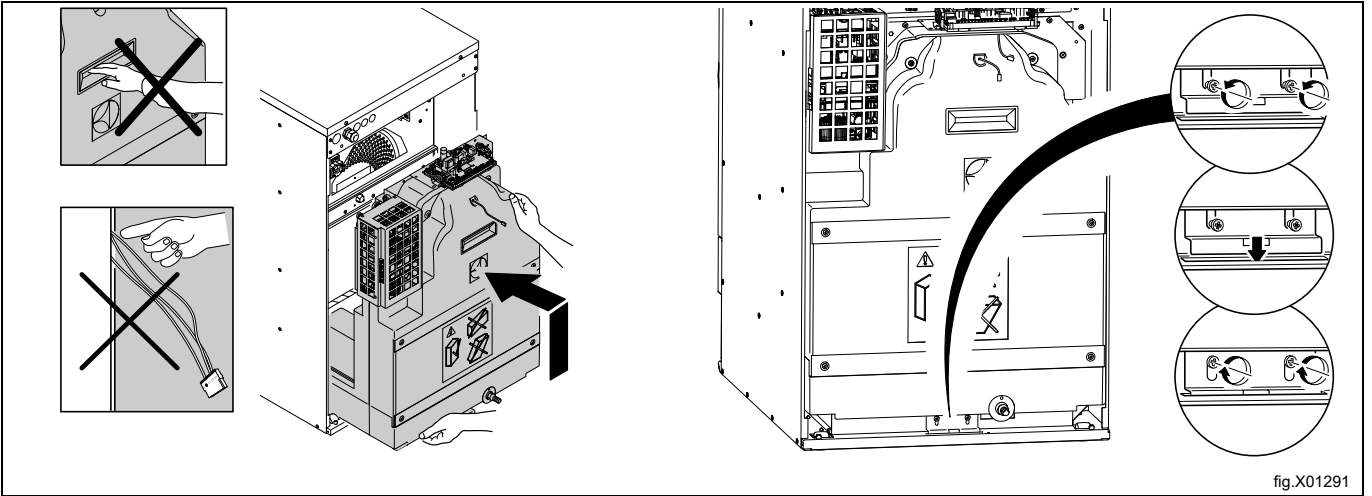

fig.X01291

Fasten the four screws on the top of the heat pump unit.

Connect the cables to the heat pump unit.

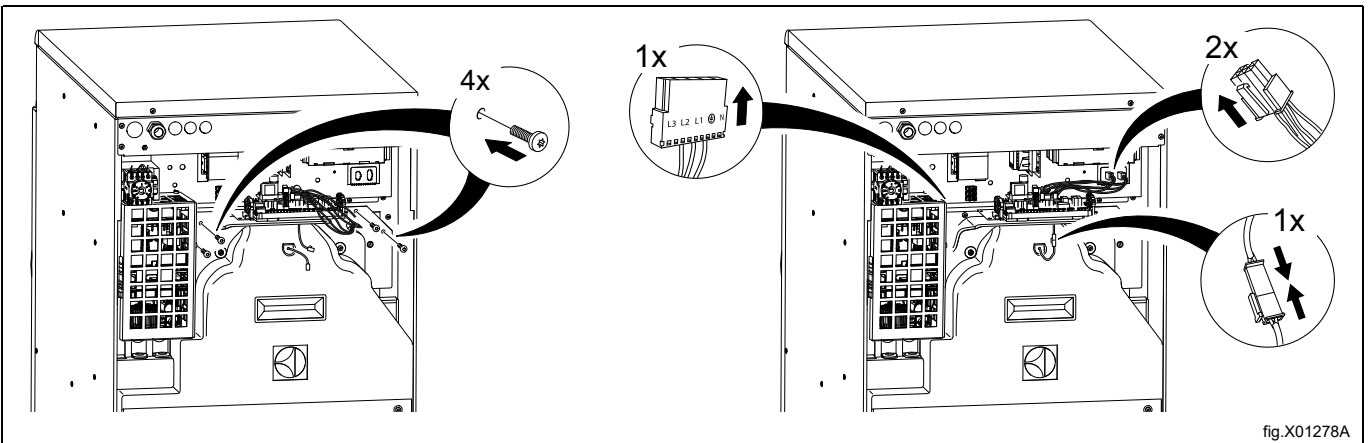

fig.X01278A

Remount the rear panel.

Connect the hose to the drain (if a hose was disconnected).

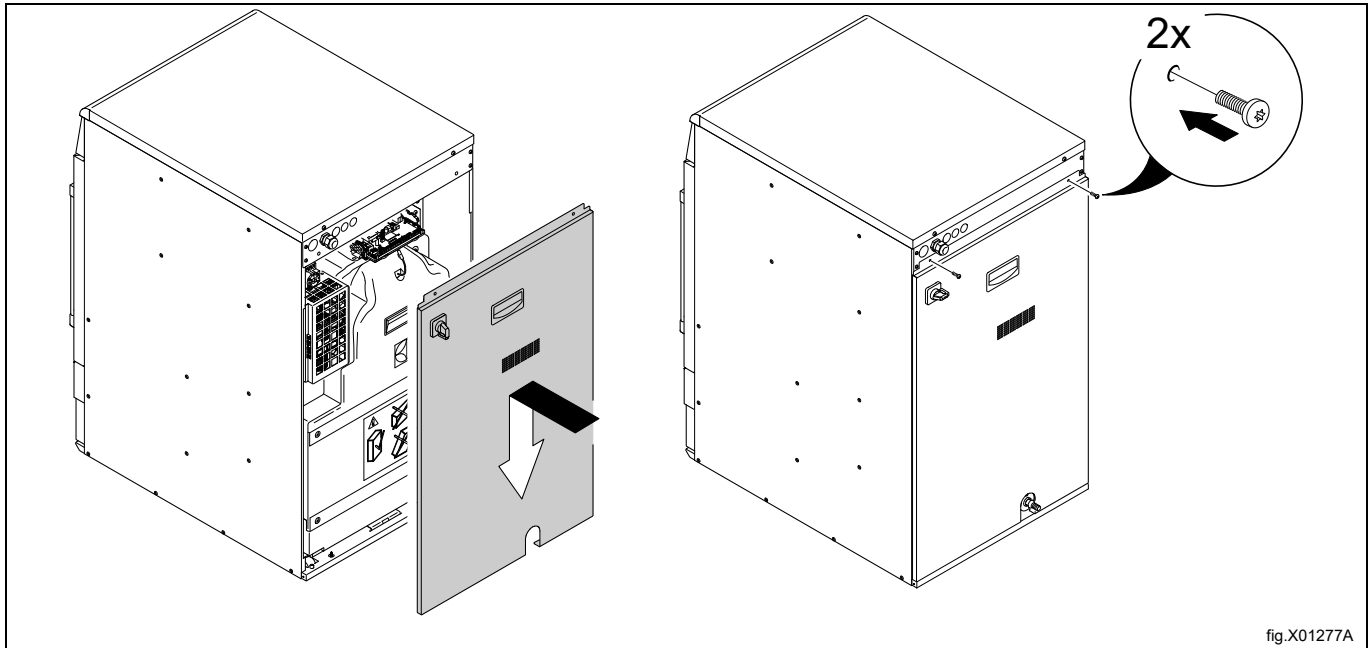

fig.X01277A



Electrolux Professional AB
341 80 Ljungby, Sweden
www.electroluxprofessional.com