

**725374 (RE471FN)**

1-door Refrigerator 670lt, -2+10°C, digital, stainless steel, R290

Main Features

- Automatic defrost
- Large storage area suitable to contain 2/1 GN grids or shelves on anti-tilt runners.
- Operating temperature can be adjusted from -2 to +10 °C to suit different food storage requirements.
- Right hinged full door.
- Cabinet fitted with up to 75 mm thickness of cyclopentane insulation for best insulating performance with 100% environmental protection (thermal conductivity: 0,020 W/m*K).
- Hidden evaporator thus guaranteeing higher storage capacity and less corrosion problems.
- Internal structure with numerous charging positions available to host grids, ensuring higher net capacity and a greater storage space.
- 60 mm-thick insulation covering the evaporator can be easily removed with a single operation.
- Optimized back to front forced air flow provide even temperature distribution and fast cooling in any conditions.
- Equipped with single phase electrical cable and Schuko plug for easy and fast installation.
- Tropicalized unit

Construction

- Lockable door.
- Mounted on adjustable Stainless steel feet, with castors as an option.
- The rounded internal corners, the easily removable runners and grids allow for ease of cleaning and high hygiene standards.
- Easy access to the main components for maintenance.
- Stainless steel runners and supports easily disassembled.
- Anti-corrosion bottom material avoids any damage that may be caused to the cabinet by aggressive detergents employed to clean the floors.
- Doors are self-closing and can be fully opened up to 180°.
- AISI 430 stainless steel internal structure and external panels.



User Interface & Data Management

- Large digital white-digit display with cabinet temperature display and setting, activation of turbo frost cycle (to rapidly cool warm loads) and possibility to activate manually the defrost cycle.
- Easy serviceability thanks to the intuitive control panel with access via app.
- Integrated RS485 port to facilitate connection to a remote computer and integrated HACCP systems.





A focus on sustainability

Sustainability

- Automatic evaporation of the defrosting water by hot gas on the top for energy saving.
- Cleaning-free condenser: the structure of the wire frame condenser prevents dust and grease accumulation thus avoiding periodical cleaning operations and reducing energy consumption.
- Door switch stops the fan when door is opened to avoid cold air exiting the cell, thus saving energy.
- Removable triple-chamber balloon magnetic gasket to improve insulation and reduce energy consumption and ease of cleaning.
- CFC and HCFC free, highly ecological refrigerant type: R290 (ecological gas in foam: cyclopentane). Hydrocarbon refrigerant gas R290 for the lowest environmental impact (GWP=3), to reduce green house and ozone depletion effects.

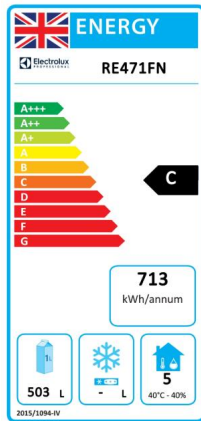
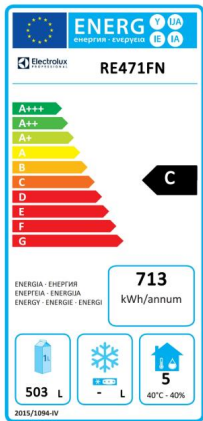

EU energy labelling from 1st July 2016

The European energy labelling scheme for professional refrigerators and freezers is based on requirements setting Minimum Energy Performance standards for commercial refrigeration cabinets sold within the EU. These requirements are designed to drive energy efficiency and environmentally friendly approach for professionals. The European energy labelling scheme will apply to all manufacturers and importers who sell and market products within the EU and it is mandatory across Europe. Important: all products which consume energy above the minimum level will not be able to be sold within the EU from 1 July 2016. SI 2020 No. 1528.

Important: all products which consume energy above the minimum level will not be able to be sold within the EU from 1 July 2016.

Certifications & Recognitions



International system for mutual acceptance of test reports and certificates concerning the safety of electrical and electronic components, equipment, and products.



Product assessed by the manufacturer and deemed to meet EU safety, health, and environmental protection requirements.



Find out more:
ISO Certificates
Electrolux Professional Recognitions

The company reserves the right to make modifications to the products without prior notice. All information correct at time of printing.

2026/04/20

3/7

Technical specifications

Electric

Supply voltage:	220-240 V/1 ph/50 Hz
Electrical power max.:	0.2 kW
Compressor power:	1/5 hp

Key Information:

Number and type of grids (included):	3 (GN 2/1)
Net Volume:	503 lt
External dimensions, Width:	710 mm
External dimensions, Depth:	835 mm
External dimensions, Depth with Doors Open:	1480 mm
External dimensions, Height:	2050 mm
Number and type of doors:	1 Full
Type of external material:	Stainless Steel AISI 430
Type of internal material:	Stainless Steel AISI 430
Internal panels material:	Stainless Steel AISI 430
Number of positions & pitch:	44; 30 mm
Gross capacity:	670 liter
Type of model:	Vertical chilled

Refrigeration Data

Control type:	Digital
Refrigeration power at evaporation temperature:	-10 °C
Operating temperature min.:	-2 °C
Operating temperature max.:	10 °C
Operating mode:	Ventilated

Sustainability

Refrigerant type:	R290
GWP Index:	3
Refrigeration power:	278 W
Refrigerant weight:	70 g
Energy Class (EU Reg. 2015/1094):	C
Climate class (EU Reg. 2015/1094):	Heavy Duty (5)
Energy Efficiency Index-EEI (EU Reg. 2015/1094):	49,67

ISO Certificates

ISO Standards:	ISO 9001; ISO 14001; ISO 45001; ISO 50001
Type reference/certification group:	VIMGTNHC

Installation drawings

Front

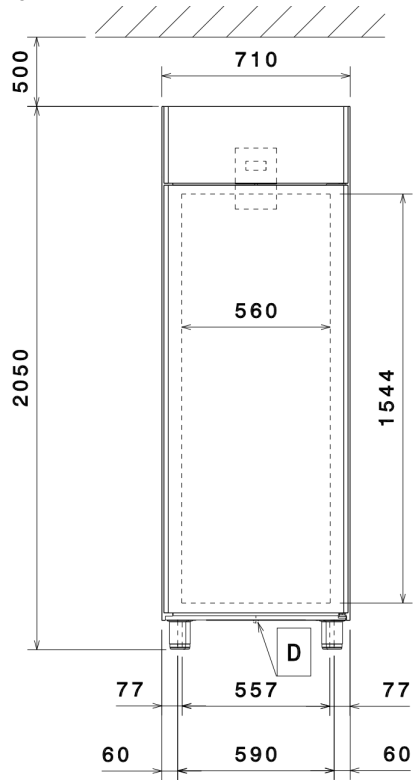

Side

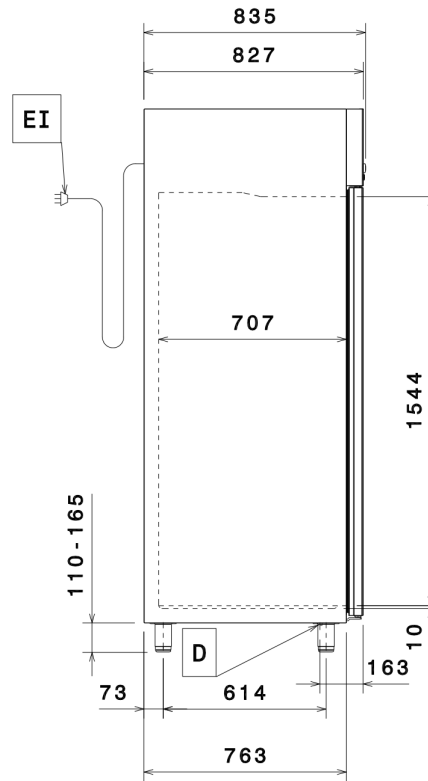

Top

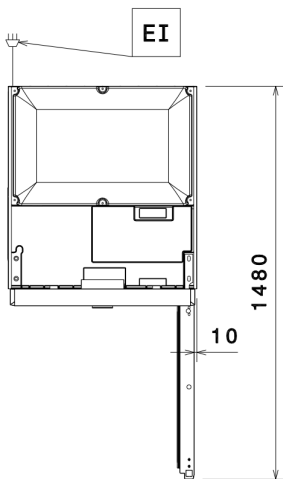

Distances

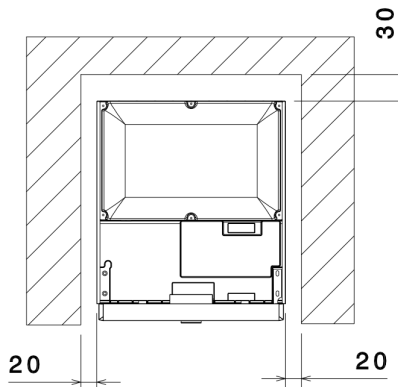

EI = Electrical inlet (power)
RI = Refrigerant Inlet

RO = Refrigerant Outlet

Accessories

Included Accessories

PNC Code	Description	Quantity
881020	2/1GN grey rilsan grid with 2 runners	3

Optional Accessories

PNC Code	Description
----------	-------------

Baskets

881043	1/1GN rilsan steel wire basket h=150mm
--------	--

Containers, trays and grids

880242	2 stainless steel runners for refrigerated cabinets - (Marine)
880243	Set of 8 GN1/1 PVC containers for fish
880248	Spacer for 670 lt and 1430 lt refrigerated cabinets
880333	Kit 20 pair runners and tray supports to fit pastry trays (400x600mm)
880705	1/1GN plastic container with false bottom
881003	Kit of 10 pairs of runners and 4 tray supports to fit pastry trays (400x600mm)
881004	2/1GN grey rilsan grid
881016	2/1GN aisi 304 stainless steel grid
881018	2/1GN 304 AISI stainless steel grid with 2 runners
881019	Meat rail for 670/1430lt refrigerators with 4 hooks
881020	2/1GN grey rilsan grid with 2 runners
881021	Set of 2 stainless steel runners for 670/1430lt refrigerators and freezers
881039	2/1GN pvc container with lid and 2 runners
881042	2/1GN perforated shelf
881044	3 grey rilsan central grids for 1430lt (not for glass door)
881047	2/1GN grey rilsan basket+2 runners h=150mm

Feet, wheels and ramps

880324	Pedal opening for cabinets
881002	4 swivelling wheels (2 with brake), diam 125 mm, for refrigerators, NOT for remote models
881035	Kit of 4 small swivelling wheels, 2 with brake, diam 50 mm, not for remote models

Other accessories

880570	Kit remote alarm
880685	Ethernet connectivity kit IJF for Refrigeration
881298	IoT module for refrigerated cabinets and counters
922432	POE switch

Accessories

Recommended Detergents

PNC Code	Description
OS2881	S01 STAINLESS STEEL SURFACE POLISHER; 6 BOTTLES X 750ML C/T
OS2883	S03 ALCOHOL BASE DETERGENT; 6 BOTTLES X 750ML; ADR&IMDG&IATA Limited Quantity
OS2884	S04 GLASSES & HARD SURFACES CLEANERS; 6 BOTTLES X 750ML
OS3257	S05 - MULTIPURPOSE DEGREASER; 6PCS X 750ML; ADR&IMDG Limited Quantity