

**710001 (EH2HBAA)**

2-door Refrigerated Counter 290lt, -2+10°C, AISI 304

**Main Features**

- Adjustable temperature range from -2 °C to +10 °C to suit meat, fish and dairy storage requirements.
- Anti-tilt runners accept GN 1/1 containers.
- Self closing stainless steel doors (< 90°).
- Prearranged to fit RS485 port to facilitate connection to a remote computer and integrated HACCP systems.
- 0mm clearance installation space: lower configuration cooling unit guarantee performance with frontal ventilation only; this unique solution allows installation against the wall or side by side with other appliances, even on the cooling unit side to maximize the use of kitchen space.
- Preservation performances and temperature uniformity within the cell guaranteed at 5-HEAVY DUTY (40°C) working conditions according to EN16825:2016 test protocol.
- Equipped with Optiflow forced air circulation system for rapid cooling and temperature distribution within the cell.
- Combination of doors and drawers to suit any configuration needed, with the possibility to change the configuration on site. Right cooling unit available on request
- Fully removable cooling unit to facilitate maintenance.
- Frontal and easy access to all components in the cooling unit.
- Certified safety CE requirements.
- Tropicalized unit

**Construction**

- Developed and produced in ISO 9001 and ISO 14001 certified factory.
- Fault code display.
- Interior base with rounded corners, pressed from a single sheet
- Internal and external doors, front and side panels and removable worktop in AISI 304 Stainless steel.
- Worktop in AISI 304 Stainless steel with a 50 mm profile.
- Built-in refrigeration unit.
- Anti-drip profile on stainless steel worktop edge.
- 2 compartments with 2 doors.
- If needed, working top can be removed for easier handling during installation (in case of narrow doors).
- Mounted on stainless steel feet to give 150 mm (-5/+50 mm) clearance for ease of cleaning the floor.
- External bottom panel in stainless steel.
- External back panel in galvanized steel.
- Ease of cleaning and high hygiene standards thanks to the rounded internal corners, the easily removable runners, grids and air conveyors.



- Internal structure with 15 charging positions (3 cm pitch) available to host GN 1/1 grids, ensuring higher net capacity and a greater storage space.

## User Interface & Data Management

- Fully compliant HACCP digital control: when temperature exceeds critical limits, acoustic and visual alarms are activated. Up to two months of event are kept in memory.
- Large digital white-digit display with cabinet temperature display and setting, and possibility to select the desired levels of humidity. Bluetooth technology included allows to keep HACCP historical data and download them through the app.
- Large digital white-digit display with humidity selection button (3 preset level), internal temperature display and setting, manual activation of defrost cycle and turbo frost cycle (to rapidly cool warm loads).
- Electrolux Professional Fridge Control APP makes the life easier for our customers:
  - Monitor safety of preservation process thanks to HACCP data & alarms for precise control
  - Save time and easy data management having the possibility to send the HACCP information in excel format directly to e-mail address
  - Quick operations: set the cabinet temperature/humidity/turbocooling and set date/hour





# A focus on sustainability

## Sustainability

- Removable triple-chamber balloon magnetic gasket to improve insulation and reduce energy consumption and ease of cleaning.
- CFC and HCFC free, highly ecological refrigerant type: R290 (ecological gas in foam: cyclopentane). Hydrocarbon refrigerant gas R290 for the lowest environmental impact (GWP=3), to reduce green house and ozone depletion effects.
- Frost Watch Control starts automatically the defrosting process only when needed and ends once ice is melted, improving energy efficiency results.
- Top energy efficiency (class A) and granted uniformity even at extreme working conditions (class 5; 40°C and 40% humidity): unbeatable performance, certified by energy test protocol EN16825:2016.
- Fitted with 90 mm thickness of cyclopentane insulation for best insulating performance (thermal conductivity: 0,020 W/m\*K) and lowest environmental impact (GWP=3).
- Hydrocarbon refrigerant gas R290 for the lowest environmental impact (GWP=3) - CFC and HCFC free.
- Hot gas automatic evaporation of defrost water.

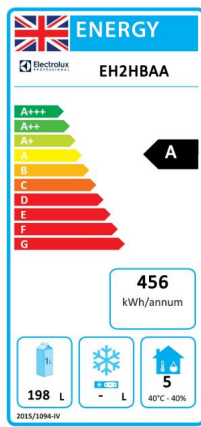
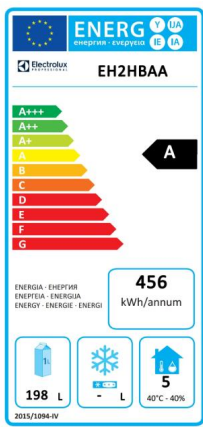

### EU energy labelling from 1st July 2016

*The European energy labelling scheme for professional refrigerators and freezers is based on requirements setting Minimum Energy Performance standards for commercial refrigeration cabinets sold within the EU. These requirements are designed to drive energy efficiency and environmentally friendly approach for professionals. The European energy labelling scheme will apply to all manufacturers and importers who sell and market products within the EU and it is mandatory across Europe. Important: all products which consume energy above the minimum level will not be able to be sold within the EU from 1 July 2016. SI 2020 No. 1528.*

**Important:** all products which consume energy above the minimum level will not be able to be sold within the EU from 1 July 2016.

## Certifications & Recognitions



International system for mutual acceptance of test reports and certificates concerning the safety of electrical and electronic components, equipment, and products.



Product assessed by the manufacturer and deemed to meet EU safety, health, and environmental protection requirements.



Find out more:  
ISO Certificates  
[Electrolux Professional Recognitions](#)

The company reserves the right to make modifications to the products without prior notice. All information correct at time of printing.

2026/04/25

3/6

# Technical specifications

## Electric

Supply voltage:	220-240 V/1 ph/50 Hz
Electrical power max.:	0.25 kW
Defrost Power:	0.22 kW
Plug type:	CE-SCHUKO
Compressor power:	1/4 hp

## Key Information:

Net Volume:	198 lt
External dimensions, Width:	1345 mm
External dimensions, Depth:	700 mm
External dimensions, Height:	900 mm
Internal Dimensions, Width:	798 mm
Internal Dimensions, Depth:	560 mm
Internal Dimensions, Height:	550 mm
Net weight:	104 kg
Shipping volume:	1.14 m <sup>3</sup>
Depth with doors open:	1110 mm
Height adjustment:	-5/50 mm
Gross capacity:	290 liter

## Refrigeration Data

Control type:	Digital
Refrigeration power at evaporation temperature:	-10 °C
Min/Max internal humidity:	40/85
Operating temperature min.:	-2 °C
Operating temperature max.:	10 °C
Operating mode:	Ventilated
Insulation:	90 mm (Cyclopentane)

## Sustainability

Refrigerant type:	R290
GWP Index:	3
Refrigeration power:	320 W
Refrigerant weight:	70 g
Energy Class (EU Reg. 2015/1094):	A
Climate class (EU Reg. 2015/1094):	Heavy Duty (5)
Energy Efficiency Index-EEI (EU Reg. 2015/1094):	19,86

## ISO Certificates

ISO Standards:	ISO 9001; ISO 14001; ISO 45001; ISO 50001
Type reference/certification group:	H7NTN2BHC

# Installation drawings

Front

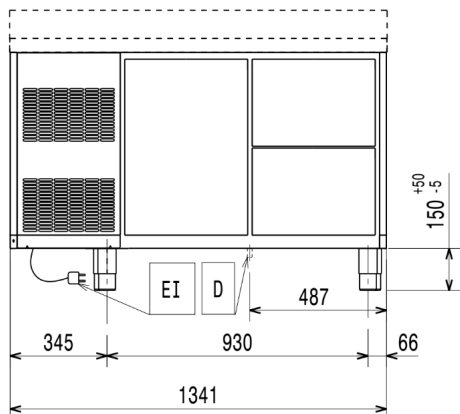

Side

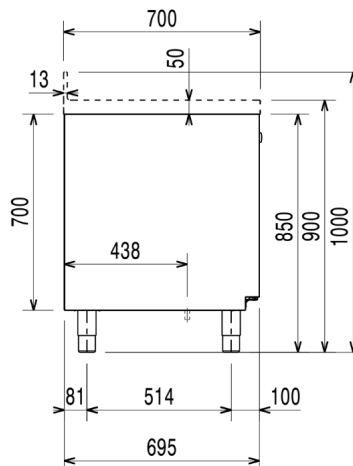

Top

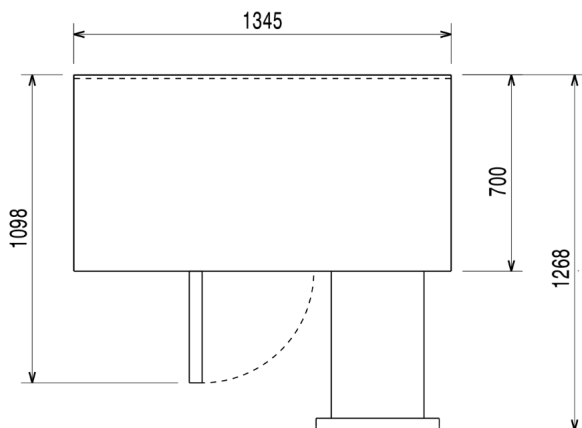

Other

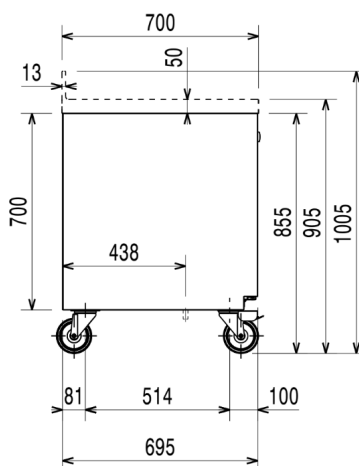

EI = Electrical inlet (power)

# Accessories

## Included Accessories

PNC Code	Description	Quantity
881109	Kit 1/1 grey rilsan grid and 2 side runners for refrigerated counters	2

## Optional Accessories

PNC Code	Description
----------	-------------

### Containers, trays and grids

881107	1/1GN grey rilsan grid for refrigerated counters
881108	2 side runners for 1/1 GN ecostore refrigerated counters
881109	Kit 1/1 grey rilsan grid and 2 side runners for refrigerated counters
881110	1/1 GN plastic container, H=65 mm
881111	1/1 GN plastic container, H=100 mm
881112	1/1 GN plastic container, H=150 mm

### Doors and drawers

881058	2x½ drawer kit for refrigerated counters
881059	3x1/3 drawer kit for refrigerated counters
881071	1/3 and 2/3 bottle drawer kit for refrigerated counters
881242	Lock for refrigerator/freezer counters with 2 compartments - h700mm (can be used in kit for Marine conversion)

### Feet, wheels and ramps

881191	Kit 4 wheels, H=100 mm (2 with brakes) for refrigerated counters
881193	Kit 4 wheels, H=150 mm (2 with brakes) for 2&3 compartment refrigerated counters

### Other accessories

881298	IoT module for refrigerated cabinets and counters
--------	---

## Recommended Detergents

PNC Code	Description
OS2881	S01 STAINLESS STEEL SURFACE POLISHER; 6 BOTTLES X 750ML C/T
OS2883	S03 ALCOHOL BASE DETERGENT; 6 BOTTLES X 750ML; ADR&IMDG&IATA Limited Quantity
OS2884	S04 GLASSES & HARD SURFACES CLEANERS; 6 BOTTLES X 750ML
OS3257	S05 - MULTIPURPOSE DEGREASER; 6PCS X 750ML; ADR&IMDG Limited Quantity