

Warewashing
Undercounter WSC, double skin, drain
pump, detergent & rinse aid dispensers,
720d/h

ITEM # _____

MODEL # _____

NAME # _____

SIS # _____

AIA # _____

502706 (ELA13G)

Undercounter Dishwasher with WASH-SAFE CONTROL, double skin, built-in drain pump, detergent and rinse aid dispensers, 3 phase, 720d/h

Short Form Specification

Item No. _____

Unit shall be green&clean undercounter dishwasher type hot water rinsing using rack dimension of 500*500mm with WASH SAFE CONTROL. Electrical characteristics to be 400 volts three phase 50Hz operation, convertible to single phase on-site. Washing performance is ensure by a powerful wash pump, large capacity wash tank, upper and lower revolving spray arms. Soft start wash pump to avoid accidental breakage of crystal wares. Constant rinse temperature and pressure guaranteed by built-in atmospheric boiler and rinse booster pump. Unit to feature "Wash-Safe Control" led light. Green light will indicate that all washed items have been properly rinsed. Uses 2.5 liters of clean water per final rinse. Three automatic cycles for different types of wares. Double skin insulated, counter-balance door. Double skin cabinet. Pressed wash tank with round corners. 304 AISI stainless steel construction to include door, external panels, frame, wash tank, tank fillers, wash arms and rinse arms. Electronic control with temperature display. Automatic self-cleaning cycle. The unit shall include drain pump, detergent and rinse aid dispenser pumps and is equipped with electric cable.

Main Features

- Incorporated Soft Start feature to offer additional protection to more delicate items.
- Washing system endowed with rotating washing arms, high powered wash pump and large capacity boiler for professional washing.
- 4 second (variable) pause after washing and before rinsing ensures that no drops of unclean water will fall on the clean items at the end of the rinsing cycle.
- Fully automatic self-cleaning cycle avoids the risk of bacteria proliferation.
- Simple control panel with digital display allows on-site personalization of washing and rinsing cycle times and temperatures as well as precise rinse aid and detergent quantities to suit customer's needs.
- Simple service from the front.
- IPx4 water protection.
- Digital read-out keeps operator informed as to temperatures.
- State-of-the-art electronic controls with built-in programming, self-diagnostics for serviceability and automatic interior self-cleaning cycle.
- Unique temperature interlock guarantees required temperatures in both the wash and final rinse in case of emergency cold water feeding.
- Constant temperature of 84 °C throughout the rinsing cycle regardless of the network's water pressure and temperature.
- Double skinned insulated wall ensures a low noise level and a reduction in heat loss from the machine.
- Green light of "WASH SAFE CONTROL" confirms that items have been rinsed properly.
- High efficiency air gap (class A) in water inlet circuit to avoid water being siphoned back into the network as a result of a sudden drop in main pressures.
- Low noise level.
- Three phase or single phase electrical connection, convertible on-site.
- Washing capacity of 40 baskets or 720 dishes per hour.
- Slanted wash arms to avoid detergent-filled wash water dropping on clean dishes after the rinsing phase, thus guaranteeing ideal washing results.
- Built-in atmospheric boiler sized to raise incoming water to 84 °C minimum for sanitizing rinse. No external booster is required.
- Solid double skinned counter-balance door with hurt-free handle fully in stainless steel.
- An effective rinse system uses only 2,5 litres of clean hot water per basket for lower running costs.
- Built-in rinse aid and detergent dispenser with automatic initial and continuous cycle loading for perfect result while minimizing service and maintenance needs.

Construction

- Unit to feature smooth surfaces to facilitate cleaning.
- 304 stainless steel boiler with higher welding

APPROVAL: _____

- protection to increase resistance to corrosion.
- PVC water supply hose with metal connections resistant to high water pressure.
- Completely closed on the back by a cover plate.
- Element protection from dry fire and low water.
- Interchangeable wash/rinse arms screw out for simple clean up.
- The boiler drain facilitates the evacuation of stagnant water after long periods of inactivity to ensure a higher level of hygiene.
- Incorporated drain pump to control water level in wash tank draining.
- Large deep drawn wash tank and internal wash area with round corners and no pipes to avoid dirt built-up.
- Revolving Stainless steel wash/rinse arms above and below the basket.
- Large tank filter collects the soil to keep the wash water clean for a longer time and have better washing performance.
- Front panel, door, wash tank, tank filters, wash arms and rinse arms made in heavy duty anti-corrosive 304 AISI stainless steel.

- Half size basket for plates PNC 864528
- Half size basket for glasses PNC 864529
- Kit 4 plastic boxes for cutlery - yellow PNC 865574
- Basket for 18 dinner plates - yellow PNC 867002
- Basket for 5 trays 530x325 mm - red, for undercounter (top level), utensil dishwashers, hood type, rack type PNC 867006
- Basket for 48 small cups or 24 cups - blue PNC 867007
- Wire basket for 12 plates up to 320 mm PNC 867014
- Cover rack for small and light items (500x500 baskets) PNC 867016
- Basket for long stem wine glasses PNC 867019
- Basket for 16 vertical glasses (h 70 mm - diam 100 mm) - blue PNC 867023
- Basket semi-professional 500x500x190mm PNC 867024

Sustainability



- Pre-arrangement for HACCP system implementation and Energy Management device.
- Unit to feature drain pump, rinse aid and detergent dispenser pumps.

Included Accessories

- 2 of Yellow cutlery container PNC 864242
- 1 of Basket for 18 dinner plates - yellow PNC 867002
- 1 of Basket for 48 small cups or 24 cups - blue PNC 867007

Optional Accessories

- 8lt external automatic water softener PNC 860005
- 12lt external manual water softener PNC 860412
- Stand for undercounter dishwasher PNC 860418
- 20lt external manual water softener PNC 860430
- External detergent level probe kit PNC 864004
- External rinse aid level probe kit PNC 864005
- Kit 4 castors for double skin undercounter dishwashers PNC 864008
- Kit 4 flanged feet for undecounter dishwashers PNC 864009
- Stainless steel inlet hose kit PNC 864016
- Filter for partial demineralization PNC 864017
- External reverse osmosis filter for undercounter and hood type dishwashers with atmosphere boiler PNC 864026
- Kit to measure total and partial water hardness PNC 864050
- Yellow cutlery container PNC 864242
- Filter for total demineralization PNC 864367
- External reverse osmosis filter for single tank Dishwashers with atmosphere boiler and Ovens PNC 864388
- Pressure reducer for single tank dishwasher PNC 864461
- Half size basket universal PNC 864527

Front

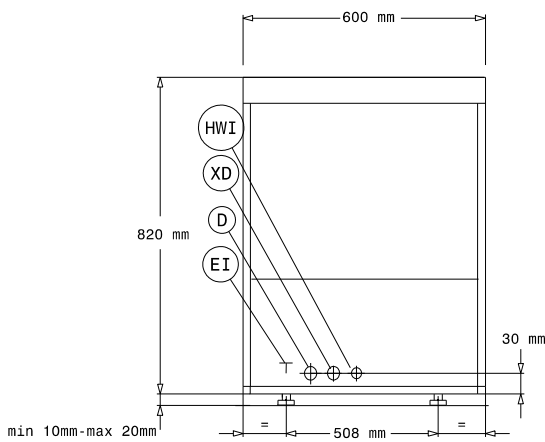

Side



* With drain pump
 ** Without drain pump

D = Drain
 EI = Electrical inlet (power)
 EO = Electrical Outlet
 HWI = Hot water inlet
 XD = Detergent connection
 XR = Rinse aid connection

Top

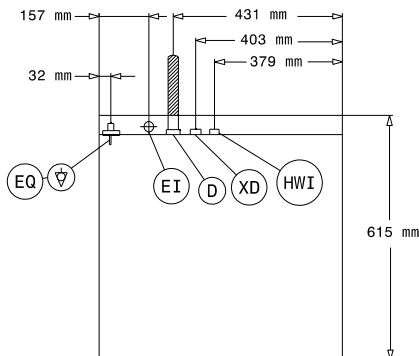
Electric

Supply voltage:	400 V/3N ph/50 Hz
Convertible to:	230V 3~; 230V 1N~
Default Installed Power:	5.35 kW
Boiler heating elements:	4,5 kW
Tank heating elements:	2 kW
Wash pump size:	0.736 kW

Water:

Pressure, min-max:	0.5-7 bar
Water supply temperature*:	50 °C
Drain line size:	20.5mm
Inlet Water supply pressure:	7 - 102 psi (0.5 - 7 bar)
Washing tank capacity (lt):	23
Water consumption per cycle (lt):	0 / 2.5
Boiler Capacity (lt):	12

Key Information:

Wash temperature:	55-65°C
Cell dimensions - width:	500 mm
Cell dimensions - depth:	500 mm
Cell dimensions - height:	335 mm
Rinse temperature:	84 °C
External dimensions, Width:	600 mm
External dimensions, Depth:	615 mm
External dimensions, Height:	820 mm
Packaging size (WxDxH):	740x670x1020 mm
Baskets per hour:	40
Dishes per hour:	720
Program Cycle time:	90/120/240

Sustainability

Noise level:	61 dBA
--------------	--------