

400313 (ETUCLG3)

Undercounter Dishwasher (L), touch control, single skin with pressure boiler, rinse aid+detergent pumps, drain pump, tank filters, max. 65 r/h, 3 phase



What the OnE Connected App can do for you?

- **Connect:** Manage your undercounter dishwasher anytime with seamless Bluetooth connectivity.
- **Control:** Gain instant insights into consumptions and savings directly from your mobile.
- **Customize:** Choose the cycle that best fits your needs, or create a personalized one, to ensure spotless results every time.

Main Features

- 4 second (variable) pause after washing and before rinsing ensures that no drops of unclean water will fall on the clean items at the end of the rinsing cycle.
- Built-in rinse aid and detergent dispenser with automatic initial and continuous cycle loading for perfect result while minimizing service and maintenance needs.
- IPx4 water protection.
- State-of-the-art electronic controls with built-in programming, self-diagnostics for serviceability and automatic interior self-cleaning cycle.
- Three phase or single phase electrical connection, convertible on-site.
- Unique temperature interlock guarantees required temperatures in both the wash and final rinse in case of emergency cold water feeding.
- Fully automatic self-cleaning cycle avoids the risk of bacteria proliferation.
- Washing system endowed with rotating integrated washing & rinsing arms in composite material, high powered wash pump and large capacity boiler for professional washing.
- Simple service from the front for technical purpose, by top for electronic boards; by lower panel for main components.
- An effective rinse system uses only 2.1/2.4 liters of clean hot water per basket for lower running costs.
- Max. theoretical washing capacity in ideal condition of 65 racks or 1170 dishes per hour, with fast cycle available on APP.
- Smooth opening for easy loading.
- Touch button user interface provide useful information using different colours reflecting appliance status; and LED icons.
- App allows on-site customization of the washing cycles, as well as adjusting chemicals dosage. It provides on time feedback of the appliance and alarm info.



- The pump filter inside the tank protects the washing pump by soil penetration with its extended surface, keeping the washing water clean.
- The single piece upper & lower arms clip-on type, interchangeable, easy to remove & reinstall. The combined washing & rinsing spraying system guarantees extended water coverage inside the chamber for excellent washing performance.
- Built-in pressure boiler sized to raise incoming 55-65 °C water to guarantee the right rinsing temperature for sanitizing rinse. No external booster is required.

Construction

- Element protection from dry fire and low water.
- Incorporated drain pump to control water level in wash tank draining.
- The boiler drain facilitates the evacuation of stagnant water after long periods of inactivity to ensure a higher level of hygiene.
- Unit to feature smooth surfaces to facilitate cleaning.
- Front and side panels, door and wash tank made in heavy duty anti-corrosive AISI 304 stainless steel.
- 304 stainless steel boiler with higher welding protection to increase resistance to corrosion.
- PVC water supply hose with metal connections resistant to high water pressure.
- Completely closed on the back by a cover plate.
- Large wash tank with round corners and no pipes to avoid dirt built-up.
- Unit to feature rinse aid and detergent dispenser pumps.
- Light & thicker moulded tank filters in composite material prolong the cleanliness of the water, collecting the major part of the soil; that can be easily removed during operations.
- Double skin insulated door.





A focus on sustainability

Sustainability

- Average energy consumption 260watt/cycle with MyEco Cycle.
- Washing cycles and chemicals setup adjustable by App.
- Water consumption 2.1 lt/rack with **MyEco cycle**.
- The cardboard packaging on pallet is fully recyclable. The cardboard is made of 70% recycled material, and FSC*-certified paper, printed with with eco-friendly ; to ensure complete sustainability and environmental responsibility. (* Forest Stewardship Council which is the world's leading organization for sustainable forestry-uses).
- ErgoCert 4-star certification for ergonomic design and ease of use. Simple operation through the user-friendly interface, and ergonomic design ensures minimal stress on the user. Colored touchpoints on removable components ensure fast cleaning operations.
- Product lifecycle extension thanks to easy access for service technician, dedicated diagnostic support and troubleshooting procedure and availability of spare parts for at least 10 years.
- Reduced energy consumption up to 40% respect to previous range, equivalent to more than 3.000kWh saved in a year, and reduced water usage up to 2lt, both based on UL Certification* leading to only 0.08kg of CO₂ equivalent per cycle. (*Calculation by energy consumption during product usage (36 cycles/day for 300 days/year), considering a mix of energy sources as by calibrated EU database upd. values [kgCO₂eq /KWh] - Source: IEA 2020 released in 2023 - The EIA Emissions Factors are specified for Electricity & Heat CO₂ and include CH₄ and N₂O factors, according to IEA for 2021 also. Comparison made between NeoBlue Touch with MyEco cycle and the previous Electrolux Professional Undercounter range with 3lt water consumption/cycle).

Package type	Package material	Weight	% Recycled	Recyclable	Certified
Box on pallet	Pallets wood FOR 50	1.00	100.00		
Box on pallet	Boxes in corrugated cardboard PAP 20	1.00	100.00		
Box on pallet	Water-based ink	1.00	100.00		

Certifications & Recognitions



International system for mutual acceptance of test reports and certificates concerning the safety of electrical and electronic components, equipment, and products.



Product assessed by the manufacturer and deemed to meet EU safety, health, and environmental protection requirements.



Awarded for its ease of use and smooth ergonomic design, it confirms its human-centered approach.



UL Verification is an independent, science-based process that validates marketing claims, helping separate verified facts from fiction.

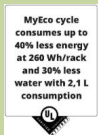

UL Verification is an independent, science-based process that validates marketing claims, helping distinguish verified facts from fiction.



Find out more:
ISO Certificates
Electrolux Professional Recognitions

The company reserves the right to make modifications to the products without prior notice. All information correct at time of printing.

2026/04/25

3/7

Technical specifications

Electric

Supply voltage:	380-415 V/3N ph/50 Hz
Convertible to:	230V 3~; 230V 1N~
Default Installed Power:	5 kW
Boiler heating elements:	4,5 kW
Tank heating elements:	2 kW
Wash pump size:	0.55 kW

Water:

Water supply temperature*:	55-65 °C
Drain line size:	20.5mm
Inlet Water supply pressure:	29 - 73 psi (2 - 5 bar)
Washing tank capacity (lt):	22
Water consumption per cycle (lt):	2.1 / 2.4
Boiler Capacity (lt):	5,8
Pressure, bar min/max:	2-5 bar

Key Information:

Baskets per hour (fast*/glasses*/multipurpose & cups/intensive*/MyEco):	65 / 40 / 36 / 24 / 15
Working cycles time (sec.):	55 / 90 / 100 / 150 / 240
Dishes per hour:	1170 / 720 / 648 / 432 / 270
Wash temperature:	55-65°C
Cell dimensions - width:	520 mm
Cell dimensions - depth:	540 mm
Cell dimensions - height:	400 mm
Rinse temperature:	60-85 °C
External dimensions, Width:	572 mm
External dimensions, Depth:	623 mm
External dimensions, Height:	830 mm
Packaging size (WxDxH):	740x670x1000 mm

Sustainability

Noise level:	<70 dBA
--------------	---------

Performance table (norm EN IEC 63136:2019)

Tested wash cycle:	myEco
Average cycle time (Tc), sec.:	440
Power ready-to-use mode (Pu), kW:	0.19
Water consumption for initial fill (Vs), l:	21.5
Average energy consumption (Ec), kWh:	0.26
Average water consumption (Vc), l:	2.1
Average program time (Tpr), sec.:	262

Installation drawings

Front

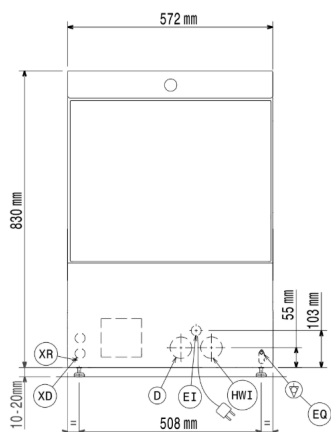

Side

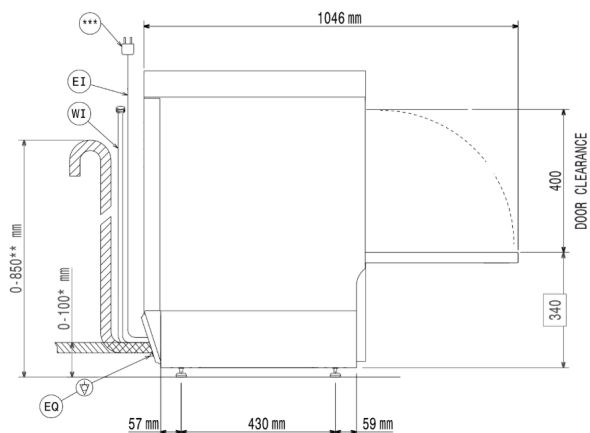

* Without drain pump
 ** With drain pump
 ***Plug only for Single Phase Machine

Top

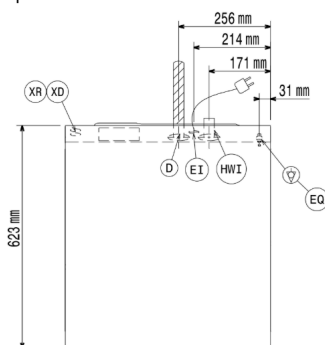

D = Drain
 HWI = Hot water inlet
 EO = Electrical Outlet

EI = Electrical inlet (power)
 XD = Detergent connection

Accessories

Included Accessories

PNC Code	Description	Quantity
864242	Yellow cutlery container	1
867002	Basket for 18 dinner plates - yellow	1

Optional Accessories

PNC Code	Description
----------	-------------

Baskets

864242	Yellow cutlery container
864527	Half size basket universal
864528	Half size basket for plates
864529	Half size basket for glasses
865574	Kit 4 plastic boxes for cutlery - yellow
867000	Basket for 12 soup bowls - green
867001	Basket for 16 soup bowls/dinner plates - blue
867002	Basket for 18 dinner plates - yellow
867003	Basket for 12 plates up to 300 mm - blue
867006	Basket for 5 trays 530x325 mm - red, for undercounter (top level), utensil dishwashers, hood type, rack type
867007	Basket for 48 small cups or 24 cups - blue
867008	Basket for 24 tilted cups - blue
867016	Cover rack for small and light items (500x500 baskets)
867020	Baskets for 16 tilted glasses (h 120 mm - diam 100 mm) - blue
867023	Basket for 16 vertical glasses (h 70 mm - diam 100 mm) - blue
867030	Basket for 16 tilted glasses (h 170 mm - diam 100 mm) - blue
867040	Baskets for 16 tilted glasses (h 220 mm - diam 100 mm) - blue

Installation solutions

860418	Stand for undercounter dishwasher
864492	Rinse booster pump kit (50Hz) for NeoBlue Undercounter
864493	Side caps for NeoBlue Undercounter
864494	Drain pump kit for NeoBlue Undercounter
864495	Kit wash tank filters in composite material (1 central support and 2 filters) for NeoBlue Undercounter

Water treatment

860005	8lt external automatic water softener
864017	Filter for partial demineralization
864050	Kit to measure total and partial water hardness
864367	Filter for total demineralization

Other accessories

864531	ELECTRICAL CONNECTOR FOR CHEMICALS PROBE KITS - UC TOUCH
--------	--

Accessories

Recommended Detergents

PNC Code	Description
0S2092	C11 Detergent for dishwashers; one pack of 2 cans of 5lt
0S2093	C13 ECO Detergent for dishwashers; one pack of 2 cans of 5lt
0S2094	C12 Rinse aid for dishwashers; one pack of 2 cans of 5lt
0S2281	C11 Detergent for dishwashers; 1 can of 20lt
0S2362	C30 Multipurpose descaler; one pack of 2 cans of 5lt
0S2904	C15 ECO Rinse aid for dishwashers; one pack of 2 cans of 5lt