

371071 (E7FRGH2GF0)

15+15-lt gas Fryer free standing with 2 "V" shape wells (external burners), 2 baskets and lids included

Main Features

- All major compartments located in front of unit for ease of maintenance.
- Deep drawn V-Shaped wells.
- Flame failure device on each burner.
- Four high efficiency 7 kW burners in stainless steel with flame failure device attached to the outside of the well.
- Gas appliance supplied for use with natural or LPG gas, conversion jets supplied as standard.
- IPx4 water protection.
- Overheat protection thermostat as standard on all units.
- Piezo spark ignition for added safety.
- Thermostatic regulation of oil temperature up to a maximum of 185 °C.
- Unit to be mounted on 50mm height adjustable feet in stainless steel.
- Oil drains through a tap into a drainage container positioned under the well.
- Optional portable oil quality monitoring tool (code 9B8081) for efficient oil management.

Construction

- Interior of well with rounded corners for ease of cleaning.
- Model has right-angled side edges to allow flush fitting joints between units, eliminating gaps and possible dirt traps.
- One piece pressed 1.5 mm work top in Stainless steel.
- All exterior panels in Stainless Steel with Scotch Brite finishing.

Included Accessories

PNC Code	Description	Quantity
206350	Door for open base cupboard	2
921691	1 full size basket for 14/15lt fryers	2



Optional Accessories

PNC Code	Description
Bases & base accessories	
206350	Door for open base cupboard
Baskets	
921691	1 full size basket for 14/15lt fryers
921692	2 half size baskets for 14/15lt fryers
Chimney upstands	
206132	Draught diverter, 150 mm diameter
206133	Matching ring for flue condenser, 150 mm diameter
206246	Flue condenser for 1 module, 150 mm diameter
206304	Chimney upstand, 800mm
206400	Chimney grid net, 400mm (700XP/900)
Cleaning solutions	
921694	Blades with rounded sides for scraper for multifunctional cookers
Feet, wheels and ramps	
206135	Kit 4 wheels - 2 swivelling with brake - it is mandatory to install Base support and wheels
206136	Flanged feet kit
206210	Kit 4 feet for concrete installation (not for 900 line free standing grill)
206367	Base support for feet or wheels - 800mm (700/900)
206368	Base support for feet or wheels - 1200mm (700/900)
206369	Base support for feet or wheels - 1600mm (700/900)
206370	Base support for feet or wheels - 2000mm (700/900)
Gas nozzles	
206467	Kit G.25.3 (NI) gas nozzles for 900 fryers
Grease/oil management	
206235	Sediment tray for 15lt fryers
206301	Oil drain pipe for 15lt free standing fryer
921693	Filter for fryer oil collection basin for 7lt, 14lt, 15lt free standing fryers
921695	Unclogging rod for 15lt fryers drainage pipe
921696	Deflector for floured products for 15lt fryers
Handrails	
206307	Right and left side handrails
206308	Back handrail 800 mm
Installation solutions	
206086	Junction sealing kit



PNC Code	Description
Kicking strips	
206148	Frontal kicking strip for concrete installation, 800mm
206150	Frontal kicking strip for concrete installation, 1000mm
206151	Frontal kicking strip for concrete installation, 1200mm
206152	Frontal kicking strip for concrete installation, 1600mm
206176	Frontal kicking strip, 800mm (not for refr-freezer base)
206177	Frontal kicking strip, 1000mm (not for refr-freezer base)
206178	Frontal kicking strip, 1200mm (not for refr-freezer base)
206179	Frontal kicking strip, 1600mm (not for refr-freezer base)
206249	Pair of side kicking strips
206265	Pair of side kicking strips for concrete installation
Other accessories	
927225	Pressure regulator for gas units
Panels	
206374	Rear paneling - 800mm (700/900)
206375	Rear paneling - 1000mm (700/900)
206376	Rear paneling - 1200mm (700/900)
216000	2 side covering panels for free standing appliances



Technical specifications

Gas

Gas Power:	28 kW
Standard gas delivery:	Natural Gas G20 (20mbar)
Gas Type Option:	LPG; Natural Gas
Working pressure, mBar (min/Max):	0 / 0
Gas Inlet:	1/2"

Key Information:

Usable well dimensions (width):	240 mm
Usable well dimensions (height):	505 mm
Usable well dimensions (depth):	380 mm
Well capacity:	13 lt MIN; 15 lt MAX
Thermostat Range:	105 °C MIN; 185 °C MAX
Net weight:	85 kg
Shipping weight:	98 kg
Shipping height:	1130 mm
Shipping width:	820 mm
Shipping depth:	860 mm
Shipping volume:	0.8 m ³
Certification group:	N7FG

Front

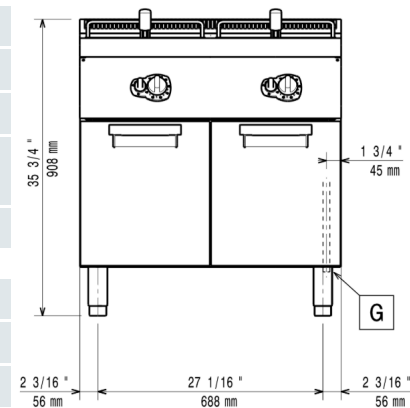

Side

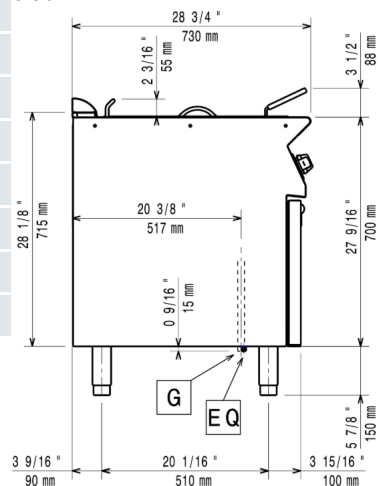

Top

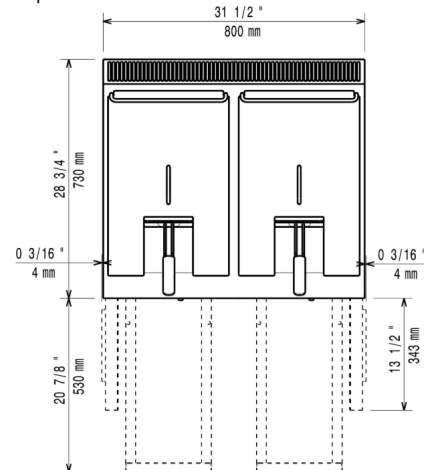

G = Gas connection
 EQ = Equipotential screw
 DO = Overflow drain pipe



Find out more:
 ISO Certificates
 Electrolux Professional Recognitions

The company reserves the right to make modifications to the products without prior notice. All information correct at time of printing.

04/03/2026