

**217746 (ECOG202T3G30)**

SkyLine PremiumS Combi Boiler Oven with touch screen control, 20x2/1GN, gas, 3 cooking modes (automatic, recipe program, manual), automatic cleaning, 3-glass door

Main Features

- 6-point multi sensor core temperature probe for maximum precision and food safety.
- Programs mode: a maximum of 1000 recipes can be stored in the oven's memory, to recreate the exact same recipe at any time. The recipes can be grouped in 16 different categories to better organize the menu. 16-step cooking programs also available.
- Dry, hot convection cycle (25 °C - 300 °C): ideal for low humidity cooking.
- Combination cycle (25 °C - 300 °C): combining convected heat and steam to obtain humidity controlled cooking environment, accelerating the cooking process and reducing weight loss.
- Low temperature Steam cycle (25 °C - 99 °C): ideal for sous-vide, re-thermalization and delicate cooking.
Steam cycle (100 °C): seafood and vegetables.
High temperature steam (101 °C - 130 °C).
- Built-in steam generator for highly precise humidity and temperature control according to the chosen settings.
- Real humidity control based upon Lambda Sensor to automatically recognize quantity and size of food for consistent quality results.
- Fan with 7 speed levels from 300 to 1500 RPM and reverse rotation for optimal evenness. Fan stops in less than 5 seconds when door is opened.
- Automatic fast cool down and pre-heat function.
- MultiTimer function to manage up to 60 different cooking cycles at the same time, improving flexibility and ensuring excellent cooking results. Can be saved up to 200 MultiTimer programs.
- Automatic mode including 9 food families (meat, poultry, fish, vegetables, pasta/rice, eggs, savory and sweet bakery, bread, dessert) with 100+ different pre-installed variants. Through Automatic Sensing Phase the oven optimizes the cooking process according to size, quantity and type of food loaded to achieve the selected cooking result. Real time overview of the cooking parameters. Possibility to personalize and save up to 70 variants per family.



- Cycles :
 - Regeneration (ideal for banqueting on plate or rethermalizing on tray),
 - Low Temperature Cooking (to minimize weight loss and maximize food quality) Patented US7750272B2 and related family,
 - Proving cycle,
 - EcoDelta cooking, cooking with food probe maintaining preset temperature difference between the core of the food and the cooking chamber,
 - Sous-vide cooking,
 - Static Combi (to reproduce traditional cooking from static oven),
 - Pasteurization of pasta,
 - Dehydration cycle (ideal for drying fruits, vegetables, meats, seafood),
 - Food Safe Control (to automatically monitor safety of cooking process in compliance with HACCP hygienic standards) Patented US6818865B2 and related family,
 - Advanced Food Safe Control (to drive the cooking with pasteurization factor).
- Back-up mode with self-diagnosis is automatically activated if a failure occurs to avoid downtime.
- 6-point multi sensor core temperature probe for maximum precision and food safety (optional accessory).
- OptiFlow air distribution system to achieve maximum performance in chilling/heating evenness and temperature control thanks to a special design of the chamber.
- GreaseOut: integrated grease drain and collection kit (to use the kit, the oven must be ordered as special code).
- Electrolux Professional recommends the use of treated water to guarantee optimal cooking results and extend the life of the appliance. Check local water condition to select the appropriate water filter. More info available on the website.
- SkyClean: Automatic and built-in self cleaning system with 4 automatic cycles (short, medium, intensive, rinse) and integrated descale of the steam generator.
- Short cleaning cycle: optimized cleaning cycle with a duration of just 33 minutes, improving efficiency and reducing downtime.

Construction

- 304 AISI stainless steel construction throughout
- IPX5 spray water protection certification for easy cleaning.
- Hygienic internal chamber with all rounded corners for easy cleaning.
- Integrated spray gun with automatic retracting system for fast rinsing.
- Triple thermo-glazed door with 2 hinged inside panels for easy cleaning and double LED lights line.
- Front access to control board for easy service.

User Interface & Data Management

- Pictures upload for full customization of cooking cycles.
- Trainings and guidances supporting materials easily accessible by scanning QR-Code with any mobile device.
- Make-it-mine feature to allow full personalization or locking of the user interface.
- With SkyDuo the Oven and the Blast Chiller are connected to each other and communicate in order to guide the user through the cook&chill process optimizing time and efficiency (requires optional accessory).
- SkyHub lets the user group the favorite functions in the homepage for immediate access.
- MyPlanner works as an agenda where the user can plan the daily work and receive personalized alerts for each task.
- USB port to download HACCP data, share cooking programs and configurations. USB port also allows to plug-in sous-vide probe (optional accessory).
- High resolution full touch screen interface (translated in more than 30 languages) - color-blind friendly panel.
- Automatic consumption visualization at the end of the cycle.
- Connectivity for remote real time access, easy HACCP management, equipment uptime increase, consumption tracking and energy management (requires optional accessory).





A focus on sustainability

Sustainability

- Energy Star 2.0 certified product
- Reduced power function for customized slow cooking cycles.
- Plan-n-Save function organizes the cooking sequence of the chosen cycles optimizing the work in the kitchen from a time and energy efficiency point of view.
- Wing-shaped handle with ergonomic design and hands-free opening with the elbow, making managing trays simpler. Protected by registered design (EM003143551 and related family).
- Zero Waste provides chefs with useful tips for minimizing food waste. Zero Waste is a library of Automatic recipes that aims to: - give a second life to raw food close to expiration date (e.g., from milk to yogurt) - obtain genuine and tasty dishes from overripe fruit/vegetables (usually considered not appropriate for sale) - promote the use of typically discarded food items (e.g., carrot peels).
- Save energy, water, detergent and rinse aid with SkyClean green functions.
- C22 and C25 detergents are formulated without phosphates and phosphorus (C25 is also maleic acid-free), making them safe for both the environment and human health.
- The outer cardboard packaging is made from 70% recycled materials and FSC*-certified paper, printed with eco-friendly, water-based ink to support sustainability and environmental responsibility. (*Forest Stewardship Council is the world's leading organization for sustainable forest management).
- Triple-glass door minimize your energy loss.* * Approx. -10% of idle energy consumption in convection based on test in compliance with ASTM Standard F2861-20

Certifications & Recognitions



Product assessed by the manufacturer and deemed to meet EU safety, health, and environmental protection requirements.



International system for mutual acceptance of test reports and certificates concerning the safety of electrical and electronic components, equipment, and products.



Certification for **energy efficiency**, ensuring products meet strict standards for reducing energy consumption, saving money, and helping protect the environment.



Product acceptable for use in a commercial food establishment and meets applicable construction, performance, and material requirements.



Awarded for its ease of use and smooth ergonomic design, it confirms its human-centered approach.



Ensures compliance with the quality, safety, and performance requirements for placement in the Dutch market.



UL Verification is an independent, science-based process that validates marketing claims, helping distinguish verified facts from fiction.



Find out more:
ISO Certificates
[Electrolux Professional Recognitions](#)

The company reserves the right to make modifications to the products without prior notice. All information correct at time of printing.

2026/04/24

3/8

Technical specifications

Electric

| | |
|----------------------------|----------------------|
| Supply voltage: | 220-240 V/1 ph/50 Hz |
| Electrical power max.: | 2.5 kW |
| Electrical power, default: | 2.5 kW |

Gas

| | |
|----------------------------------|---------------------|
| Total thermal load: | 340900 BTU (100 kW) |
| Gas Power: | 100 kW |
| Standard gas delivery: | Natural Gas G20 |
| ISO 7/1 gas connection diameter: | 1" MNPT |

Water:

| | |
|--------------------------------------|---------|
| Max inlet water supply temperature: | 30 °C |
| Chlorides: | <17 ppm |
| Conductivity: | 0 µS/cm |
| Drain "D": | 50mm |
| Water inlet connections "CW11-CW12": | 3/4" |
| Pressure, bar min/max: | 1-6 bar |

Capacity:

| | |
|--------------------|-------------|
| Trays type: | 20 - GN 2/1 |
| Max load capacity: | 200 kg |

Key Information:

| | |
|------------------------------|---------------------|
| External dimensions, Width: | 1162 mm |
| External dimensions, Depth: | 1066 mm |
| Weight: | 394 kg |
| External dimensions, Height: | 1794 mm |
| Net weight: | 394 kg |
| Shipping weight: | 432 kg |
| Shipping volume: | 3.09 m ³ |

ISO Certificates

| | |
|----------------|---|
| ISO Standards: | ISO 9001; ISO 14001; ISO 45001; ISO 50001 |
|----------------|---|

Installation drawings

Front

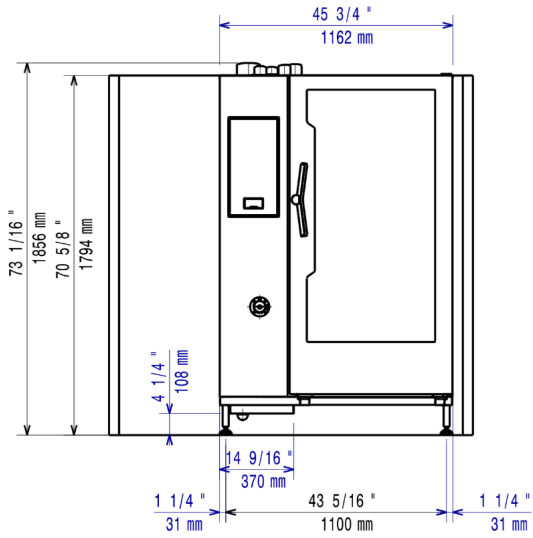

Side

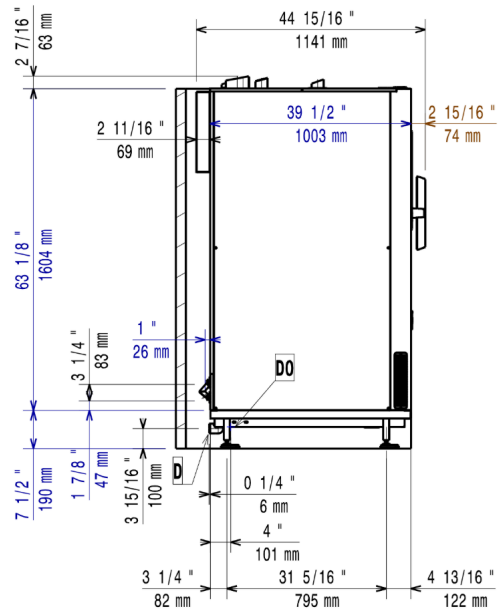

Top

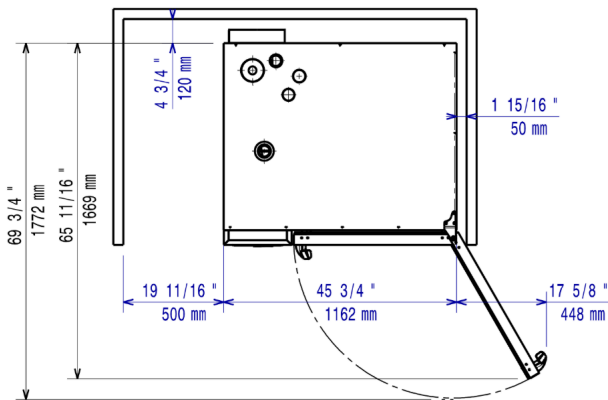

Distances

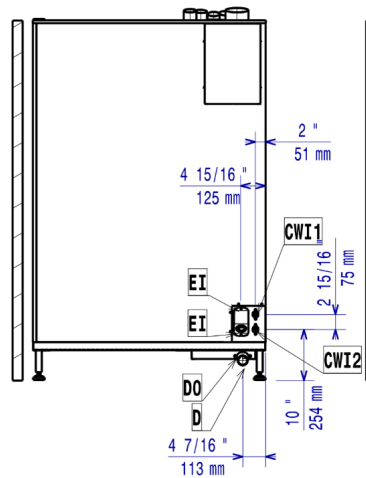

CWI1 = Cold Water inlet 1 (cleaning)
 G = Gas connection
 DO = Overflow drain pipe

D = Drain
 EI = Electrical inlet (power)

Accessories

Included Accessories

| PNC Code | Description | Quantity |
|----------|--|----------|
| 922757 | Trolley with tray rack 20 GN 2/1, 63mm pitch | 1 |

Optional Accessories

| PNC Code | Description |
|----------|-------------|
|----------|-------------|

Cleaning solutions

| | |
|--------|--|
| 922386 | Wall mounted detergent tank holder |
| 922618 | External connection kit for liquid detergent and rinse aid |

Containers, trays and grids

| | |
|--------|---|
| 922017 | Pair of AISI 304 stainless steel grids, GN 1/1 |
| 922036 | Pair of grids for whole chicken (8 per grid - 1,2kg each), GN 1/1 |
| 922062 | AISI 304 stainless steel grid, GN 1/1 |
| 922189 | Baking tray for 5 baguettes in perforated aluminum with silicon coating, 400x600x38mm |
| 922190 | Baking tray with 4 edges in perforated aluminum, 400x600x20mm |
| 922191 | Baking tray with 4 edges in aluminum, 400x600x20mm |
| 922239 | Pair of frying baskets |
| 922264 | AISI 304 stainless steel bakery/pastry grid 400x600mm |
| 922266 | Grid for whole chicken (8 per grid - 1,2kg each), GN 1/1 |
| 922348 | Multipurpose hook |
| 922362 | Grid for whole duck (8 per grid - 1,8kg each), GN 1/1 |
| 922651 | Dehydration tray, GN 1/1, H=20mm |
| 922652 | Flat dehydration tray, GN 1/1 |
| 922713 | Mesh grilling grid, GN 1/1 |
| 922746 | Tray for traditional static cooking, H=100mm |
| 922747 | Double-face griddle, one side ribbed and one side smooth, 400x600mm |
| 925001 | Non-stick universal pan, GN 1/1, H=40mm |
| 925002 | Non-stick universal pan, GN 1/1, H=60mm |
| 925003 | Double-face griddle, one side ribbed and one side smooth, GN 1/1 |
| 925004 | Aluminum grill, GN 1/1 |
| 925005 | Frying pan for 8 eggs, pancakes, hamburgers, GN 1/1 |
| 925006 | Flat baking tray with 2 edges, GN 1/1 |
| 925008 | Potato baker for 28 potatoes, GN 1/1 |
| 925012 | Kit of 6 non-stick universal pans, GN 1/1, H=20mm |
| 925013 | Kit of 6 non-stick universal pans, GN 1/1, H=40mm |
| 925014 | Kit of 6 non-stick universal pan GN 1/1, H=60mm |

Drains

| | |
|--------|--|
| 922738 | Stainless steel drain kit for 20 GN oven, dia=50mm |
|--------|--|

Accessories

| PNC Code | Description |
|---------------------------------------|---|
| Feet, wheels and ramps | |
| 922688 | 4 adjustable feet for 6 & 10 GN ovens, 100-115mm |
| 922707 | 4 flanged feet for 20 GN , 2", 100-130mm |
| 922716 | Levelling entry ramp for 20 GN 2/1 oven |
| Food probes | |
| 922281 | USB probe for sous-vide cooking |
| 922390 | USB single point probe |
| 922714 | Probe holder for liquids |
| Grease/oil management | |
| 922357 | Grease collection tray, GN 2/1, H=60 mm |
| Handling - bakery | |
| 922762 | Bakery/pastry trolley with rack holding 400x600mm grids for 20 GN 2/1 oven and blast chiller freezer, 80mm pitch (16 runners) |
| Handling - banqueting | |
| 922367 | Thermal cover for 20 GN 2/1 oven and blast chiller freezer |
| 922760 | Banquet trolley with rack holding 92 plates for 20 GN 2/1 oven and blast chiller freezer, 85mm pitch |
| 922764 | Banquet trolley with rack holding 116 plates for 20 GN 2/1 oven and blast chiller freezer, 66mm pitch |
| Handling - gastronorm | |
| 922686 | Trolley with tray rack, 15 GN 2/1, 84mm pitch |
| 922757 | Trolley with tray rack 20 GN 2/1, 63mm pitch |
| 922758 | Trolley with tray rack, 16 GN 2/1, 80mm pitch |
| Installation solutions | |
| 922658 | Heat shield for 20 GN 2/1 oven |
| 922670 | Kit to convert from natural gas to LPG |
| 922671 | Kit to convert from LPG to natural gas |
| 922739 | Plastic drain kit for 20 GN oven, dia=50mm |
| 922743 | Holder for trolley handle (when trolley is in the oven) for 20 GN oven |
| Kit compatibility air-o-system | |
| 922770 | Kit compatibility for aos/easyline trolley (produced till 2019) with SkyLine/Magistar 20 GN 2/1 combi oven |
| 922771 | Kit compatibility for aos/easyline 20 GN oven with SkyLine/Magistar trolleys |
| Other accessories | |
| 922338 | Volcano Smoker for lengthwise and crosswise oven |
| Spray units | |
| 922171 | External side spray unit (needs to be mounted outside and includes support to be mounted on the oven) |
| Ventilation | |
| 922678 | Flue condenser for gas oven |
| 922776 | Extension for condensation tube, 37cm |
| Wall mounting kits | |
| 922687 | Kit to fix oven to the wall |

Accessories

| PNC Code | Description |
|--------------------------|--|
| Water treatment | |
| 864388 | External reverse osmosis filter for single tank Dishwashers with atmosphere boiler and Ovens |
| 920003 | Water filter with cartridge and flow meter for high steam usage (combi used mainly in steaming mode) |
| 920005 | Water filter with cartridge and flow meter for medium steam usage |
| Other accessories | |
| 922326 | Universal skewer rack |
| 922328 | 6 short skewers |
| 922421 | IoT module for OnE Connected (Combi Ovens, Blast chiller/freezers, Rack Type DW) and SkyDuo (one IoT board per appliance - to connect oven to blast chiller for Cook&Chill process). |
| 922435 | Connectivity router (WiFi and LAN) |
| 922439 | SkyDuo Kit - to connect oven and blast chiller freezer for Cook&Chill process. The kit includes 2 boards and cables. Not for OnE Connected |
| 922447 | Elevating kit with trolley height extension for 20 GN 2/1 oven |
| 922448 | Baking tray with 4 edges in perforated aluminum, coated surface, 400x600x20mm |
| 922449 | Baking tray with 4 edges in aluminum, coated surface, 400x600x20mm |
| 922773 | Water inlet pressure reducer |

Recommended Detergents

| PNC Code | Description |
|----------|--|
| 0S2394 | C25 Rinse & Descale Tabs, phosphate-free, phosphorous-free, maleic acid-free, 50 tabs bucket |
| 0S2395 | C22 Cleaning Tabs, phosphate-free, phosphorous-free, 100 bags bucket |